

# General Specifications

GX20/GP20 (/CM2 option)  
GM (/CM2 and /CS2 options)  
920MHz Wireless Communication

**SMARTDAC+**<sup>TM</sup>

GS 04L51B01-42EN

## OVERVIEW

Wireless communication (902.1 to 927.9MHz band) enables the GX20(/CM2), GP20(/CM2), GM10(/CM2) to communicate as a master with compatible GM10 slaves (/CS2), UT52A/UT32A(suffix code type 3:B), and Wireless Input Unit (GX70SM), other Modbus devices and wireless communication sensors.

Because slaves are equipped with a repeater function, they can be used to extend the communication distance.

(This product can only be used in the US.)

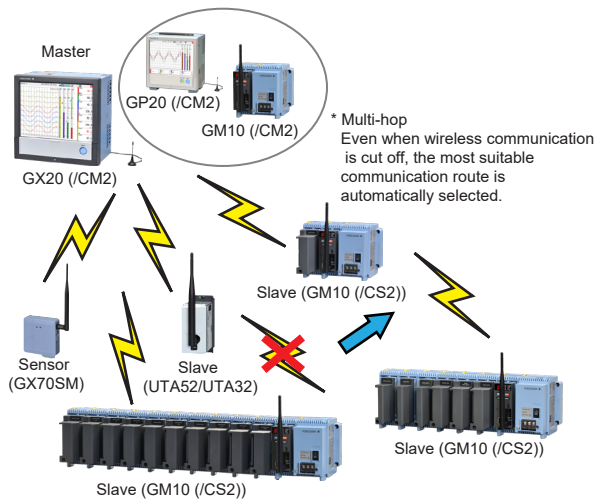

### Master

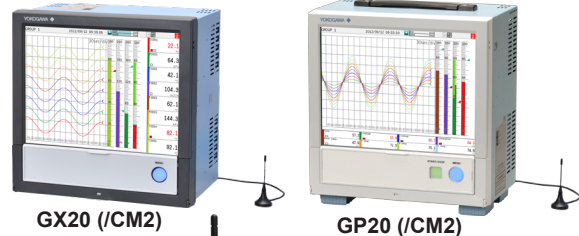

### Slave



For the detailed specifications of the GX20, see the following general specifications.

Material No.: GS 04L51B01-01EN

For the detailed specifications of the GP20, see the following general specifications.

Material No.: GS 04L52B01-01EN

For the detailed specifications of the GM10, see the following general specifications.

Material No.: GS 04L55B01-01EN

For the detailed specifications of the I/O modules, see the following general specifications.

Material No.: GS 04L53B01-01EN

For the detailed specifications of the Digital Indicating Controller, see the following general specifications.

Material No.: GS 05P01D81-01EN

Material No.: GS 05P01C81-01EN

For the detailed specifications of the Wireless Input Unit (GX70SM), see the following general specifications.

Material No.: GS 04L57B01-01EN

## Features

- A single master can accommodate up to 100 slaves.<sup>\*1</sup> This is limited to 99 for the UT.
- The output larger than that of conventional specified low power radio achieving a range of about 800 m<sup>\*2</sup> with a clear line-of-sight.
- With multi-hop connection, even when wireless communication is cut off due to temporary deterioration in radio conditions, the most suitable communication route is automatically selected to resume wireless communication. GM10 slaves (/CS2 option) and UT slaves can be used as repeaters to extend communication distance and improve radio quality.
- Features of the 900 MHz band (compared to the 2.4 GHz band)
  - Because the radio frequency is low, radio signals attenuate less in the transmission route.
  - Because the radio frequency is low and the tendency to go straight is lower, the radio signals can more easily diffract around obstacles.
  - No license is required.

\*1 The number of units that can be connected may be limited by the communication data size or the transmission interval. When used for low-speed moving bodies, the maximum number of routers is limited to 50 including repeaters.

\*2 The range depends on the operating environment.

## ■ SPECIFICATIONS

### ● 920 MHz wireless communication (/CM2 and /CS2)

- Wireless communication standard: FCC Part 15 Subpart C compliant (§15.247)
- Carrier frequency band: 902.1 to 927.9 MHz
- Wireless channel spacing: 600 kHz
- Number of wireless channels: 43
- Maximum transmission output: 20 mW
- Modulation method: GFSK
- Antenna: External antenna (sold separately), RP-SMA -P connector
- Maximum number of slave receptions: 100 (number of slave receptions by a single master, varies depending on the communication conditions)
- Maximum packet size: 2048 bytes
- Data rate: 100 kbps max.
- Communication distance \*1 (line-of-sight distance): 800 m max. (depends on the operating environment)

\*1 At an antenna height of 1.5 m or more off the ground. Communication distance varies depending on the installation location and environment.

- Communication format: Mesh/multi-hop\* (maximum number of hops: 16)

\* A function that automatically selects the best communication path according to the communication quality between units. It can be used to extend the communication distance and improve the radio quality.

- LED display: Displays the wireless status using ST1 (green/red) and ST2 (green/red)
- Security function: AES 128 bit encryption
- Implemented protocol: Modbus (master/slave) protocol
- Modbus slave function (/CS2 option): Data can be written and read from Modbus master devices (masters (/CM2 option)).
- Modbus master function\* (/CM2 option): Reading and writing data to Modbus slave device
- \* The communication channel function (/MC option) is required. Read data is written to communication channels.

Communication cycle:

When receiver function is [Modbus master]

500 ms, 1 s, 2 s, 5 s, 10 s, 1 min

When receiver function is [Wireless input unit]

1 s, 2 s, 5 s, 10 s, 20 s, 30 s, 1 min, 2 min, 5 min, 10 min, 20 min, 30 min, 1 h

Note: Only the above communication cycles will work properly.

Number of commands: 100

Command types: Off, read, write

- Configuration/measurement communication: The following functions are available using the dedicated software.  
GM10 wireless communication settings  
Information about slaves connecting to the GM10  
GM10 wireless communication status monitoring
- \* MH920 Console International, a console software application made by Oki Electric Industry Co., Ltd.



- Wireless communication configuration interface: USB 2.0 mini-B type)
- Reboot switch: For rebooting the system after changing wireless settings

### Number of connectable slaves and number of connectable channels depending on Modbus communication cycle\*

Number of slaves	Modbus communication cycle		
	500ms	1s	2s
1	125ch	370ch	500ch
2	80ch	250ch	500ch
4	---	160ch	500ch
8	---	---	320ch

\* Number of channels for 1 word data (INT16, UINT16). This varies depending on the processing load in the device and communication quality.

### Dedicated external antenna (sold separately):

Item	Type	
	Sleeve antenna	Roof top antenna
Part No.	A1061ER	A1062ER
Installation environment	Indoors	Indoors and outdoors
Cable length	—	2.5 m
Antenna type	Dipole	Standalone
Maximum gain	3 dBi or less	2 dBi or less
Directivity	No	
Connector	RP-SMA-P	
Operating temperature range	-20 to 65°C	
Waterproof property	Not waterproof	Water resistant (IPX6)
Dimensions	196 mm (including the connector)	83 mm (including the base stand)
		

Note 1) Can only be used in combination with the dedicated antenna.

Note 2) When using an external antenna, we recommend aligning the direction of the antenna of the peer device and the direction of the antenna of this device to maintain communication quality.

Note 3) To bring out the full performance of the roof top antenna, install it on top of a metal rectangle board that is at least 10 x 20 cm long.

Note 4) Install antennas as far as possible from metal objects and other obstacles. The communication quality may deteriorate if they are close.

### Compliant Standards

- GX20 (/CM2 option), GP20 (/CM2 option), GM10 (/CM2 and /CS2 options)  
Only US FCC standards and CSA/UL standards are supported.
- GM90PS (/W option)  
CSA/UL standards are not supported.

### • Wireless Input Unit Support Function of the GX20/GP20/GM10 (/CM2 option) (R4.02.01 and later)

Data collection and status monitoring of wireless input units are possible.

- Number of GX70SM connections\*

Model	Measurement mode (GX/GP/GM)			
	Normal		High speed	Dual interval
	Wireless data retrieval Off	Wireless data retrieval data On		
GX20-1 /GP20-1 /GM10-1	Max. 50 devices	Max. 30 devices	Max. 50 devices	Max. 30 devices
GX20-2 /GP20-2 /GM10-2	Max. 96 devices	Max. 50 devices	Max. 96 devices	Max. 50 devices

\* The number of technically possible connections varies depending on the wireless communication condition and the measurement/transmission interval.

- Auto configuration function  
Automatically configures the wireless input unit data collection settings.
- Wireless data dropout detection function  
Detects data collection dropouts due to wireless communication errors or the like.
- Wireless data retrieval (version 4.09 and later)\*  
\* Only available when the advanced security function (/AS option) is enabled.  
However, it cannot be used when the multi-batch function (/BT option) is enabled.  
Also wireless communication module version is v4.4.0 and later.
- Management, monitoring, and maintenance functions  
Displays wireless input unit information.  
Status monitoring and maintenance period management are available.
- Loop calibration function  
Wireless input data correction using the calibration correction function
- Web application and Hardware Configurator also support wireless input unit functions.

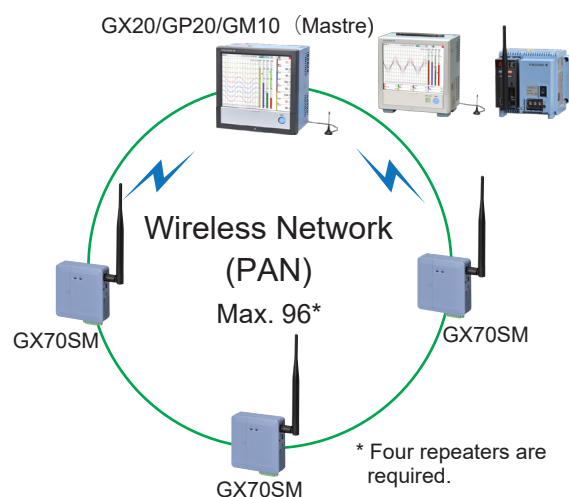

The screenshot shows the 'Wireless input unit reconfig' interface. The title bar indicates 'Wireless input unit reconfig2018/04/23 13:05:26'. The main area contains a table with columns: Number, Status, Recognized ID, Connected ID, Input, and Data serial. The table lists 10 devices with various statuses (VALID, OPENED) and associated IDs.

Number	Status	Recognized ID	Connected ID	Input	Data serial
1	VALID	55M8000001	55M8000001	C001 - C003	C004 - C005
2	OPENED	55M8000002	55M8000002	C006 - C008	C009 - C010
3	VALID	55M8000003	55M8000003	C011 - C013	C014 - C015
4	VALID	55M8000004	55M8000004	C016 - C018	C019 - C020
5	VALID	55M8000005	55M8000005	C021 - C023	C024 - C025
6	OPENED	55M8000006	55M8000006	C026 - C028	C029 - C030
7	VALID	55M8000007	55M8000007	C031 - C033	C034 - C035
8	VALID	55M8000008	55M8000008	C036 - C038	C039 - C040
9	VALID	55M8000009	55M8000009	C041 - C043	C044 - C045
10	VALID	55M8000010	55M8000010	C046 - C048	C049 - C050

At the bottom, there are controls for 'Loop time : 100ms', 'Update all connection info', and 'Reconfiguration all units'.

Wireless input unit reconfiguration display

## ■ HARDWARE SPECIFICATIONS

### ● External dimensions

Unit: mm [approx. inch]

#### GX20

##### When using the sleeve antenna

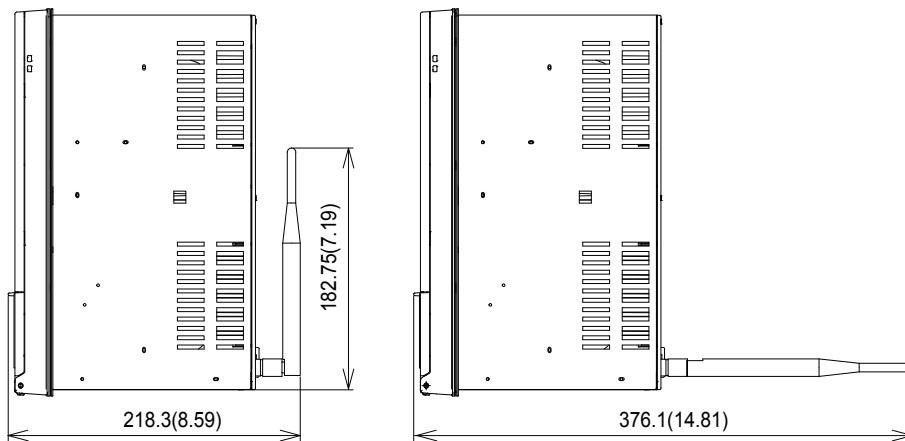

##### When using the roof top antenna

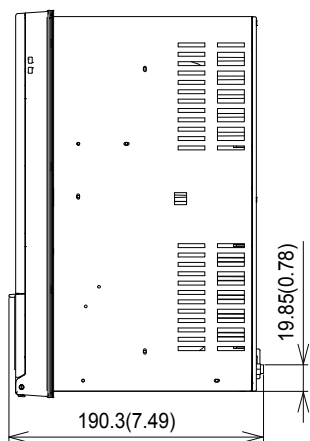

Unit: mm (approx. inch)  
 Unless otherwise specified, tolerance is  $\pm 3\%$   
 (however, tolerance is  $\pm 0.3$  mm when below 10 mm).

#### Rear view

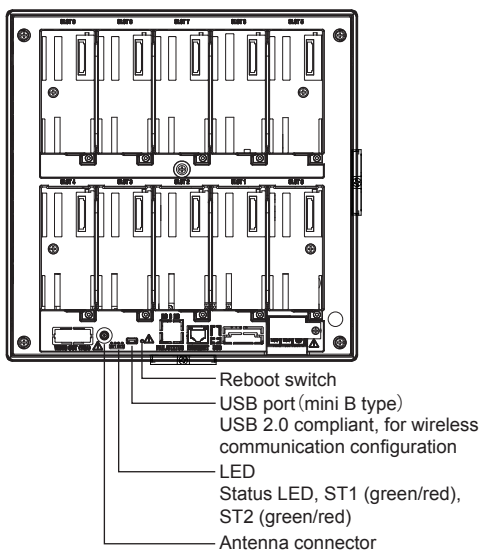

**GP20**

**When using the sleeve antenna**

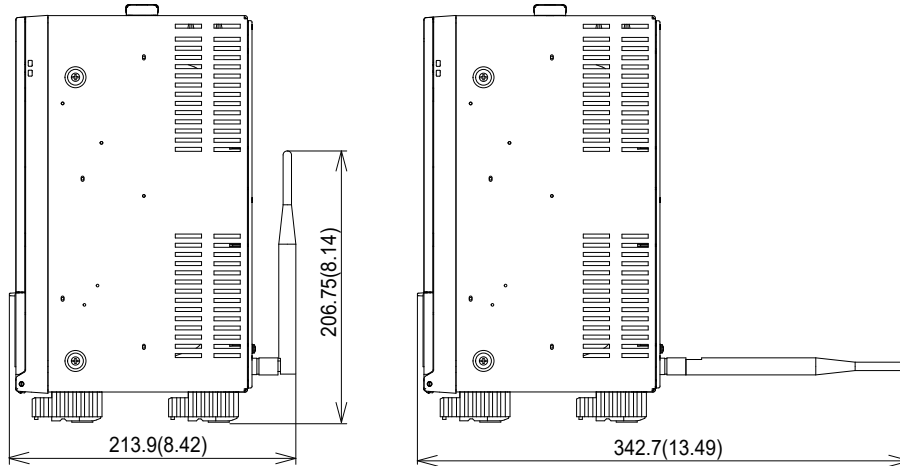

**When using the roof top antenna**

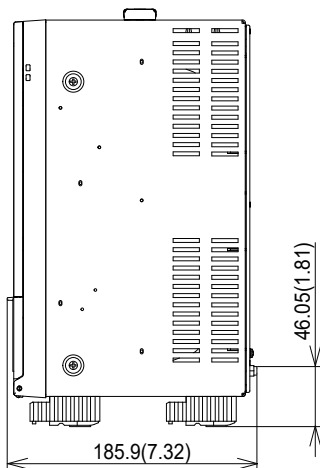

Unit: mm (approx. inch)  
 Unless otherwise specified, tolerance is  $\pm 3\%$   
 (however, tolerance is  $\pm 0.3$  mm when below 10 mm).

**Rear view**

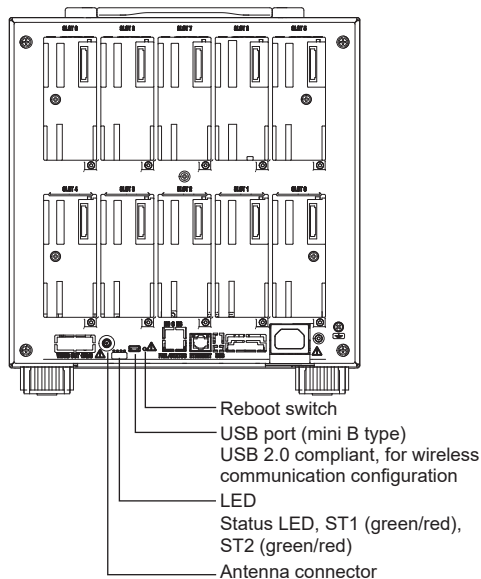

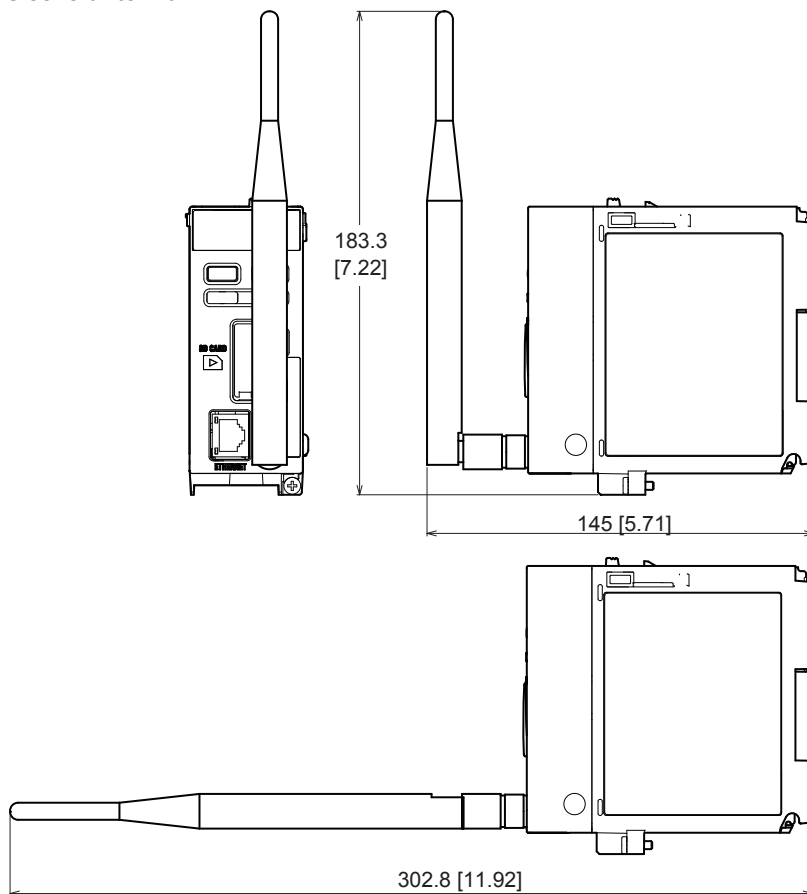
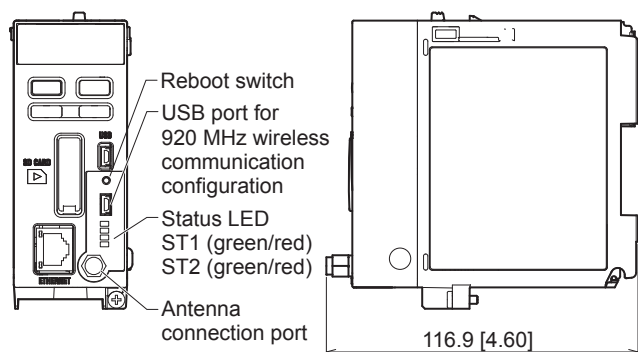
**GM10****When using the sleeve antenna****When using the roof top antenna**

## MODEL AND SUFFIX CODES

### GM90PS Model and Suffix Codes

Model	Suffix Code	Optional code	Description
<b>GM90PS</b>			Paperless recorder (Panel mount type, Large display)
Type	-1		Standard (Max. measurement channels: 100 ch)
	-2		Large memory (Max. measurement channels: 500 ch)
Display language	E		English, degF, DST (summer/winter time)
Optional features		/CM2	920 MHz wireless (Master) <sup>*1 *2 *3 *4</sup>

- \*1 /C2 and /C3 and /CM2 cannot be specified together.
- \*2 This product can only be used in the US.
- \*3 If you specify /CM2, you must also specify the communication channel function (/MC option).
- \*4 The /AS option (Advanced security function) is required to use the wireless data retrieval.

### GP20 Model and Suffix Codes

Model	Suffix Code	Optional code	Description
<b>GP20</b>			Paperless recorder (Portable type, Large display)
Type	-1		Standard (Max. measurement channels: 100 ch)
	-2		Large memory (Max. measurement channels: 500 ch)
Display language	E		English, degF, DST (summer/winter time)
Power supply	1		100 V AC, 240 V AC
	2		12 V DC
Optional features		/CM2	920 MHz wireless (Master) <sup>*1 *2 *3 *4</sup>

- \*1 /C2 and /C3 and /CM2 cannot be specified together.
- \*2 This product can only be used in the US.
- \*3 If you specify /CM2, you must also specify the communication channel function (/MC option).
- \*4 The /AS option (Advanced security function) is required to use the wireless data retrieval.

### GM10 Model and Suffix Codes

Model	Suffix code	Optional code	Description
<b>GM10</b>			Data Acquisition Module for SMARTDAC+ GM
Type	-1		Standard (Max. measurement channels: 100)
	-2		Large memory (Max. measurement channels: 500)
Area	E		General
—	0		Always zero
Optional features		/CM2	920 MHz wireless (Master) <sup>*1 *2 *3 *4</sup>
		/CS2	920 MHz wireless (Slave) <sup>*2</sup>

- \*1 If you specify /CM2, you must also specify the communication channel function (/MC option).
- \*2 /C3, /CM2, and /CS2 cannot be specified together.
- \*3 If you specify /CM2, you must also specify the communication channel function (/MC option).
- \*4 The /AS option (Advanced security function) is required to use the wireless data retrieval.

### GM90PS Model and Suffix Codes

Model	Suffix Code	Optional code	Description
<b>GM90PS</b>			Power Supply Module for SMARTDAC+ GM
Type	-1		Always -1
Area	N		General
Supply voltage	1		100-240 V AC
	2		12-28 V DC <sup>*1</sup>
Power supply connection		D	Power inlet with UL/CSA cable
		W	Screw terminal (M4) (without power cable)
—		0	Always zero
Optional features		/W	For 920 MHz wireless <sup>*2</sup>

- \*1 Only W (Screw terminal (M4)) is available for the power supply connection.
- \*2 The only power supply module that can be used with GM10's 920 MHz wireless communication (/CM2 and /CS2 options) is GM90PS-1N 1D0/W or GM90PS-1N 2W0/W.

## OPTIONAL ACCESSORIES (SOLD SEPARATELY)

Product	Model/part no.
Sleeve antenna (indoor use)	A1061ER
Roof top antenna (indoor and outdoor use, cable length: 2.5 m)	A1062ER
Validation Documents (For /AS option) <sup>*1 *2</sup>	773230

- \*1 Provision of Validation Documents  
A license sheet containing the license key required for installation is provided.  
Download the validation document from the following URL.  
<http://www.smartdacplus.com/software/en/>
- \*2 The /W option is provided to connect with GX70SM.

### Test Certificate (QIC, sold separately)

QIC is available for each model.

### User's Manual

Product user's manuals can be downloaded from the following URL. You will need Adobe Reader 7 or later by Adobe Systems.

**URL: [www.smartdacplus.com/manual/en/](http://www.smartdacplus.com/manual/en/)**

### Trademarks

The TCP/IP software used in this product and the document for that TCP/IP software are based in part on BSD networking software, Release 1 licensed from The Regents of the University of California.  
SMARTDAC+ is a trademark of Yokogawa Electric Corporation.  
Microsoft, MS, and Windows are trademarks or registered trademarks of Microsoft Corporation in the United States and other countries.  
Core2 Duo is a registered trademark of Intel Corporation.  
Modbus is a registered trademark of Schneider Electric.  
Kerberos is a trademark of MIT.  
Bluetooth is a trademark or registered trademark of Bluetooth SIG Inc.  
Other company names and product names appearing in this document are registered trademarks or trademarks of their respective holders.  
The company and product names used in this manual are not accompanied by the registered trademark or trademark symbols (® and ™).



---

## ■ Notes on 920 MHz Wireless Communication

This equipment is designed for use in the US only and cannot be used in any other country.

- **The radio signal may become weaker due to the operating environment, such as radio interference and obstacles in the communication route, leading to a communication error with the wireless communication temporarily disrupted.**

**If the radio signal continues to weaken, the communication error may continue for a long period of time.**

- **Communication may not be possible in the following locations due to the surrounding environment.**
  - Where strong magnetic field, static electricity, or radio interference occurs.
  - Rooms with metallic walls (including concrete containing metal reinforcement material), cases, shelves, gratings, windows with metal mesh, and walls with thick concrete.
  - Within warehouses for liquid containers.
- **The backfill function may not work properly if you use it in an environment with bad wireless connection, or if you do not configure or operate it in the right way.**
- **If another wireless device using the same radio frequency band as this product is present in the communication area of this product, data rate degradation or communication errors may occur, preventing normal communication.**
- **This product has obtained FCC marking. As such, the following acts may be punishable by law.**
  - Disassembling or altering the product.
  - Removing the certification label.
  - Using an antenna other than the specified option.
- **Because this product uses radio signals, bear in mind that communication may be intercepted by third parties.**

## ■ Liability

YOKOGAWA assumes no liability to any party for any loss or damage, direct or indirect, caused by lost or missing data due to interrupted wireless or cable communication, or the use of the product outside the design, specifications, or handling conditions.

Except for the matters stipulated in the warranty of this product, YOKOGAWA does not guarantee any measurement data and operation taken when there is a failure, erroneous operation, and problem with the product.