

Elcometer 3095

Buchholz Hardness Tester

Operating Instructions

en elcometer



elcometer[®] is a registered trademark of Elcometer Limited.

All other trademarks acknowledged.

© Copyright Elcometer Limited. 2015.

All rights reserved. No part of this Document may be reproduced, transmitted, transcribed, stored (in a retrieval system or otherwise) or translated into any language, in any form or by any means (electronic, mechanical, magnetic, optical, manual or otherwise) without the prior written permission of Elcometer Limited.

*Doc.No. TMA-0341 Issue 02
Text with Cover No: 19610*

CONTENTS

Section	Page
1 About your tester	2
1.1 Standards	3
1.2 What the box contains.	3
2 Getting started.	4
2.1 Fitting batteries	4
2.2 Adjusting the microscope	5
2.3 Adjusting the supporting pins	6
3 Testing a specimen.	7
4 Maintenance	13
5 Technical specification.	14
6 Spares	15
7 Related equipment	15

Thank you for your purchase of this Elcometer 3095 Buchholz Hardness Tester. Welcome to Elcometer. Elcometer are world leaders in the design, manufacture and supply of inspection equipment for coatings and concrete. Our products cover all aspects of coating inspection, from development through application to post application inspection.

The Elcometer 3095 Buchholz Hardness Tester is a world beating product. With the purchase of this product you now have access to the worldwide service and support network of Elcometer. For more information visit our website at www.elcometer.com

1 ABOUT YOUR TESTER

The Elcometer 3095 Buchholz Hardness Tester is a simple-to-use gauge for measuring the hardness of coatings on substrates using an indentation method.

The indenting tool incorporates a disc which has a sharp bevelled edge. The tool is positioned on the test specimen with the edge of the disc in contact with the coating. The mass of the tool provides a constant load between the disc and the coating.

After a set period of time the tool is removed and the length of the indentation left on the coating is observed and measured using the illuminated microscope supplied with the tester.

The length of the indentation is inversely proportional to the hardness of the coating.

1.1 STANDARDS

The Elcometer 3095 Buchholz Hardness Tester can be used in accordance with the following National and International Standards:

- BS 3900 E9
- DIN 53153
- ECCA T12 - 1985
- EN ISO NF 2815
- NF T 30-052

1.2 WHAT THE BOX CONTAINS

- Indentation tool with bevelled disc and two locating pins
- Pin adjusting shim
- Indentation locating template
- Illuminated microscope
- Hexagonal wrench
- Plastic carrying case
- Operating Instructions

To maximise the benefits of your new Elcometer 3095 Buchholz Hardness Tester please take some time to read these Operating Instructions. Do not hesitate to contact Elcometer or your Elcometer supplier if you have any questions.

2 GETTING STARTED

2.1 FITTING BATTERIES

The microscope light source is powered by two batteries. To fit the batteries, remove the light source from the microscope, rotate and remove the bulb enclosure and insert the batteries ensuring correct polarity (Figure 1). Refit the components in reverse order.



Figure 1. Microscope light source - battery polarity

If the microscope is to remain unused for long periods of time, remove the batteries and store them separately. This will prevent damage to the microscope in the event of malfunction of the batteries.

To switch on the light source, rotate the black end cap.

2.2 ADJUSTING THE MICROSCOPE

Adjust the focus and the scale of the microscope before you take a reading (Figure 2):

1. Adjust the focus on the scale by rotating the knurled rubber eyepiece.
2. Rotate the scale as required.
3. Place the microscope on a flat surface, switch on the light and adjust the focus on the specimen by rotating the large knurled ring
4. Place the microscope on a flat surface, switch on the light and adjust the focus on the specimen by rotating the large knurled ring.

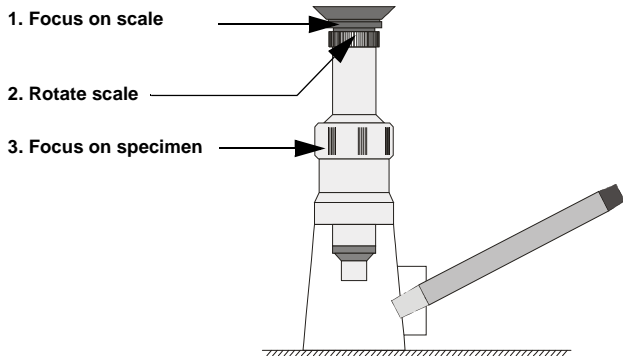

Figure 2. Microscope focusing and scale rotation

2.3 ADJUSTING THE SUPPORTING PINS



Take care when adjusting and using the indenting tool; the points of the supporting pins are very sharp and can puncture skin.

The indenting tool supporting pins have points on each end and can therefore be inverted if they become worn or damaged. To remove the pins, unscrew the hexagon screws on each side of the indenting tool. Refit the pins, tighten the hexagon screws and then adjust the length of the pins using the adjusting shim included with your tester (Figure 3):

1. Place the adjusting shim on a flat hard surface.
2. Place the indenting tool on the adjusting shim with the supporting pins in the holes in the shim.
3. Loosen the hexagon screws until the pins drop down to the surface and then re tighten the screws.

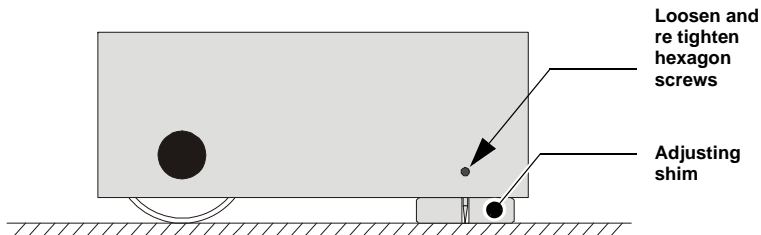

Figure 3. Adjusting the supporting pins

3 TESTING A SPECIMEN

To test a specimen, follow steps 1 to 7 below:

1. Place the indentation locating template on the specimen. Position the template with respect to the test zone as shown in Figure 4 and press down firmly against the specimen to hold the template in place.

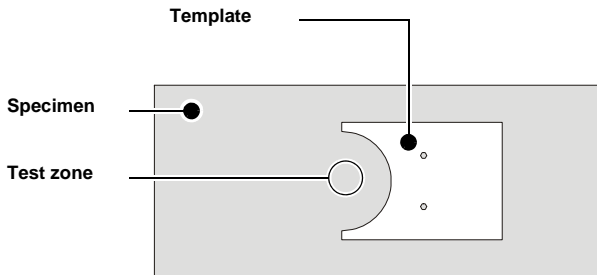
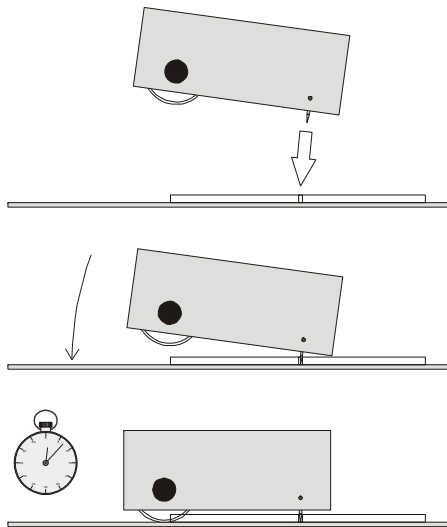

Figure 4. Template positioning

2. Hold the indenting tool angled as shown and lower it onto the template, supporting pins first, until the pins locate in the two holes in the template.
3. Rotate the indenting tool **very gently** until the bevelled disc touches the surface of the specimen (Figure 5). As soon as the disc touches the specimen, start a stop watch.
4. After 30 s, rotate the indenting tool away from the surface of the specimen and then lift it away completely taking care not to dislodge the template from its position on the specimen.



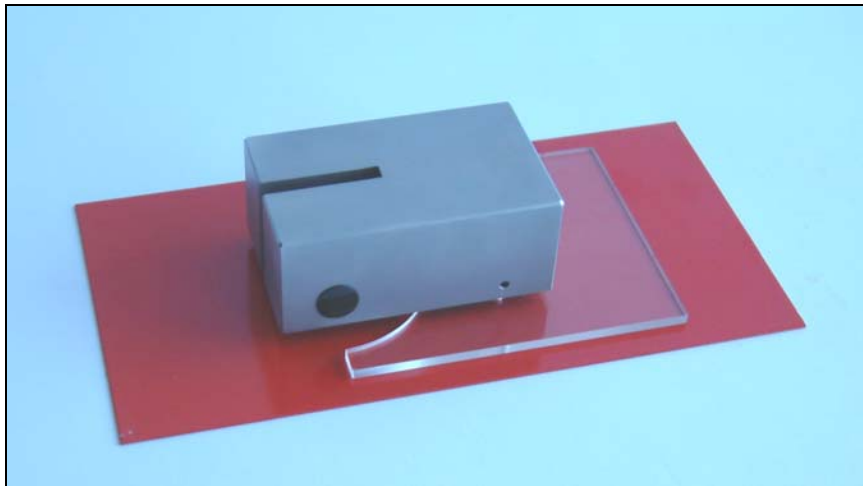

Figure 5. Indenting tool and template on a specimen

5. Keeping the template pressed down firmly against the specimen, place the microscope into the rounded shape of the template, with the light source orientated at right angles to the indentation (Figure 6).

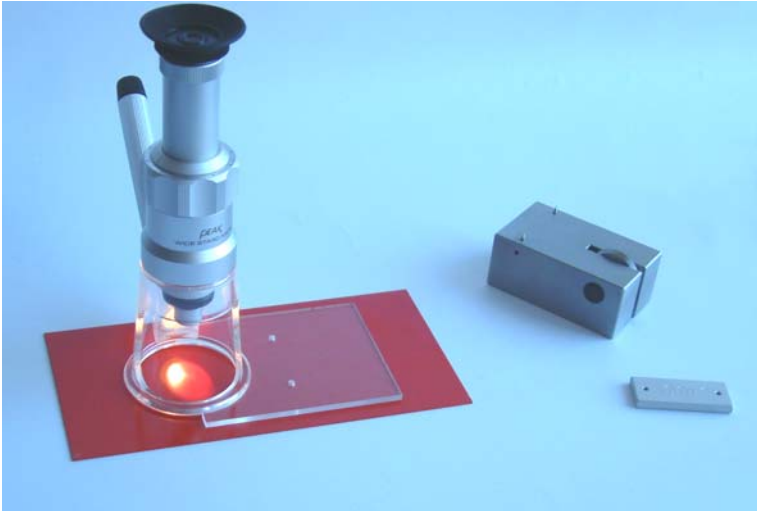

Figure 6. Microscope and template on a specimen

6. Adjust the focus, positioning and rotation of the scale of the microscope until the indentation is visible clearly and can be measured against the scale (Figure 7). Record the length of the indentation.

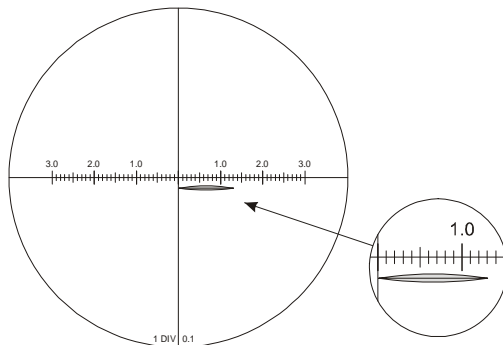

Figure 7. Typical view of indentation through microscope

7. Use the table below to determine the indentation resistance and depth.

Indentation length (mm)	Indentation resistance	Indentation depth		Minimum coating thickness for which a measurement is valid	
		(μm)	(mils)	(μm)	(mils)
0.8	125	5	0.2	15	0.59
0.85	118	6	0.24	20	0.79
0.9	111	7	0.28	20	0.79
0.95	105	7	0.28	20	0.79
1.0	100	8	0.31	20	0.79
1.05	95	9	0.35	20	0.79
1.1	91	10	0.39	20	0.79
1.15	87	11	0.43	25	1
1.2	83	12	0.47	25	1
1.3	77	14	0.55	25	1
1.4	71	16	0.63	30	1.18
1.5	67	18	0.71	30	1.18
1.6	63	21	0.83	35	1.38
1.7	59	24	0.94	35	1.38

4 MAINTENANCE

The Elcometer 3095 Buchholz Hardness Tester is designed to give many years reliable service under normal operating and storage conditions.

Store the components of the test set in a dry and clean place. Avoid contact with solvents.

4.1 Bevelled disc

If the bevelled disc in the indenter tool becomes worn, remove the black plastic cap on the side of the tool, loosen the screw, rotate the disc to expose a new sharp edge, re tighten the screw and then replace the plastic cap. Replacement discs are available as spare parts - see “Spares” on page 15 for ordering information.

4.2 Supporting pins

At regular intervals check the indenter tool supporting pins for wear; see “Getting started” on page 4 for details of how to change and adjust the pins. Replacement pins are available as spare parts - see “Spares” on page 15 for ordering information.

4.3 Microscope

Keep the lenses of the microscope clean. The lenses must be cleaned only with products suitable for use with optical components.

The tester does not contain any other user-serviceable components. In the unlikely event of a fault, the Elcometer 3095 should be returned to your local Elcometer supplier or directly to Elcometer. The warranty will be invalidated if the instrument has been opened.

Details of Elcometer offices around the world are given on the outside cover of these operating instructions. Alternatively visit the Elcometer website, www.elcometer.com

5 TECHNICAL SPECIFICATION

Load on sample:	500 g (1.1 lb)
Microscope magnification:	20 x
Scale divisions:	0.1 mm (4 mils)
Battery type:	2 x AA (LR6) 1.5 V, alkaline ^a dry batteries
Dimensions (case):	360 mm x 310 mm x 120 mm (14.2" x 12.2" x 4.7")
Weight:	2.9 kg (6.4 lb)

The Elcometer 3095 Buchholz Hardness Tester is packed in a cardboard and foam package. Please ensure that this packaging is disposed of in an environmentally sensitive manner. Consult your local Environmental Authority for further guidance.

-
- a. Alkaline batteries must be disposed of carefully to avoid environmental contamination. Please consult your local environmental authority for information on disposal in your region.

Do not dispose of any batteries in fire.

6 SPARES

The Elcometer 3095 Buchholz Hardness Tester is complete with all the items required to get started, however over the life of the tester replacements may be required.

The following replacement items are available from your local supplier or direct from Elcometer:

Description	Part Number
Supporting pins, set of 2	KT003095P001
Bevelled Hardened Steel Disc	KT003095P002

7 RELATED EQUIPMENT

In addition to the Elcometer 3095 Buchholz Hardness Tester, Elcometer produces a wide range of other equipment for determining the physical characteristics of surface coatings. Users of the Elcometer 3000 may also benefit from the following Elcometer products:

- Elcometer 3101 Barcol Hardness Tester
- Elcometer 7300 Digital Stop Watch
- Elcometer 3120 Shore Durometer
- Elcometer Washability, Brushability and Abrasion Testers
- Elcometer Scratch Testers
- Elcometer Elasticity and Deformation Testers

For further information contact Elcometer, your local supplier or visit www.elcometer.com

