

Elcometer 236

DC Holiday Detector

Operating Instructions



Safety Warning



The detector generates a high voltage at the probe tip up to 30,000 volts. The equipment should be used with extreme care, following the instructions given in this Manual.

The detector is powered by a rechargeable battery and the instrument must not be used for high voltage testing while connected to the mains electricity supply for battery charging.

For safety and reliability the detector is supplied with the battery discharged. Recharge the battery before using for the first time - see "Charging the battery" on page 35.



The Elcometer 236 DC Holiday Detector meets the emc directive 89/336/EEC, amended 92/31/EEC and 93/68/EEC. However, due to its method of operation, the Detector will generate broad band RF emissions when a spark is produced at the probe, i.e., when a defect in the coating is located. These emissions may interfere with the operation of sensitive electronic apparatus in the vicinity. In the extreme case of a continuous spark of length 5 mm, the magnitude of emissions at a distance of 3 m was found to be approximately 60 dB μ V/m from 30 MHz to 1000 MHz.

It is therefore recommended that this equipment is not operated within 30 m of known sensitive electronic equipment and that the User does not deliberately generate continuous sparks.

elcometer® is a registered trademark of Elcometer Limited.

All other trademarks acknowledged.

© Copyright Elcometer Limited. 2009.

All rights reserved. No part of this Document may be reproduced, transmitted, transcribed, stored (in a retrieval system or otherwise) or translated into any language, in any form or by any means (electronic, mechanical, magnetic, optical, manual or otherwise) without the prior written permission of Elcometer Limited.

A copy of this Instruction Manual is available for download on our Website via www.elcometer.com/downloads.

*Doc No. TMA-0214 Issue 04
Text with Cover No. 4885*

CONTENTS

Section	Page
1 About this holiday detector	4
1.1 What the box contains.	4
2 Working safely.	5
3 Holiday detection	7
3.1 The need for holiday detection	7
3.2 How your detector works.	7
4 Standards and test methods	8
5 Getting started.	11
5.1 The control panel	11
5.2 Connections and terminals	12
5.3 The probe handle	13
5.4 The carry case	14
5.5 Quick start guide	15
6 Using the Holiday Detector	16
6.1 Test batteries	16
6.2 Connect leads	16
6.3 Select probe	16
6.4 Connect high voltage return to substrate	17
6.5 Check operation of high voltage return connection	17

6.6 Set test voltage	18
6.7 Set alarm sensitivity	18
6.8 Check for correct operation	18
6.9 Inspect coating for flaws	18
6.10 Moving work position and finishing work	19
7 Static electricity	19
8 Using the current monitoring function	21
8.1 Breakdown voltage operation outline	21
9 Setting the test voltage and sensitivity	22
9.1 Dielectric strength	22
9.2 Establishing the Voltage Limits	24
9.3 Setting the test voltage	25
9.4 Setting alarm sensitivity	25
10 Probe selection	28
11 Troubleshooting	30
11.1 LCD display related problems	30
11.2 Alarm related problems	31
11.3 No spark at probe tip	31
11.4 Special considerations	32
12 Maintenance	34
12.1 Battery maintenance	34
12.2 Routine checks	36

13 Storage	36
14 Spares	37
14.1 Right angle probes	37
14.2 Circular brush probes	38
14.3 Rolling spring probes	40
14.4 Extension pieces	43
14.5 Other accessories	44
15 Technical specification	45
16 Related equipment	46

Thank you for your purchase of this Elcometer 236 DC Holiday Detector. Welcome to Elcometer.

Elcometer are world leaders in the design, manufacture and supply of inspection equipment for coatings and concrete. Our products cover all aspects of coating inspection, from development through application to post application inspection.

The Elcometer 236 DC Holiday Detector is a world beating product. With the purchase of this product you now have access to the worldwide service and support network of Elcometer. For more information visit our website at www.elcometer.com

1 ABOUT THIS HOLIDAY DETECTOR

Your Elcometer 236 DC Holiday Detector locates all flaws in insulating coatings on conductive substrates. The Holiday Detector can be used to test coatings up to 7 mm (275 mils) thick and is ideal for inspecting pipelines and other protective coatings. Coatings on concrete can also be tested using this method if the concrete contains sufficient moisture to conduct the current that flows when a flaw is detected.

To ensure safe working and to maximise the benefits of this Holiday Detector please take some time to read these Operating Instructions. Do not hesitate to contact Elcometer or your Elcometer supplier if you have any questions.

1.1 WHAT THE BOX CONTAINS

- Elcometer 236 DC Holiday Detector
- Probe handle and lead
- Band brush probe
- 2 m (79") and 10 m (394") signal return/earth leads
- Battery charger
- Operating instructions and Carrying Case

2 WORKING SAFELY



Due to the method of testing for coating flaws, this equipment outputs a very high voltage of up to 30 kV, (30 000 volts) or 15 kV (15 000 volts), on the high voltage probe.

If the user makes contact with the probe, it is possible to experience a mild electric shock. However, due to the current being very low, this is not normally dangerous.

In addition, an electrical spark indicates detection of a coating flaw, so that the method is unsuitable for use in certain situations and environments, e.g. an explosive atmosphere.

Therefore, in order to minimise injury and damage, the following guidance should always be observed:

- ✘ **DO NOT** use the equipment in any combustible, flammable or other atmosphere where an arc or spark may result in an explosion.
 - ✘ **DO NOT** carry out tests close to moving machinery.
 - ✘ **DO NOT** use in a precarious, wobbly or elevated situation from which a fall may result, unless a suitable safety harness is used.
 - ✘ **DO NOT** use in rain or a damp atmosphere.
 - ✘ **DO NOT** use the equipment if you have a pacemaker or heart condition.
 - ✘ **DO NOT** clean^a the instrument or cables with any water based or solvent based cleaning fluids; this may weaken the insulating materials and lead to the User being exposed to high voltages.
 - ✘ **DO NOT** use the Holiday Detector while the charger is connected to the unit - see “Charging the battery” on page 35.
-

a. Cleaning of the instrument to remove overspray and spots of coatings is a Service requirement. Please contact Elcometer or your local Elcometer Supplier.

elcometer

- ✓ **DO** read these instructions carefully before commencing to use the equipment.
 - ✓ **DO** charge the battery before the first use of the equipment.
 - ✓ **DO** consult the plant or safety officer before carrying out the test procedure.
 - ✓ **DO** wear rubber gloves.
 - ✓ **DO** undertake testing well clear of other personnel.
 - ✓ **DO** work with an assistant, to keep the test area clear and to help with the testing procedure.
 - ✓ **DO** check that there are no solvents or other ignitable materials from the coating activities left in the test area, particularly in confined areas such as tanks.
 - ✓ **DO** switch the detector off and disconnect the leads when the work is finished and before leaving it unattended, e.g. when charging the internal rechargeable battery.
 - ✓ **DO** ensure that the high voltage return lead is connected to the conducting substrate prior to switching on the detector.
 - ✓ **DO** only use on coatings that are cured, thickness tested and visually inspected and accepted.
 - ✓ **DO** only use on coating thickness^b of at least 200 µm (0.008"). Use the 236 with care for thickness between 200 µm and 500 µm (0.008" to 0.020").
 - ✓ **DO** be aware of the possibility of static build-up on the work surface causing static shock. To reduce this risk, wear rubber gloves and take special care when leaving confined areas such as pipes and tanks.
 - ✓ **DO** bond the work piece to a ground potential to ensure the build up of static charge does not take place - see page 19.
-

b. For thinner coatings, use the wet sponge method, e.g. Elcometer model 270.

3 HOLIDAY DETECTION

3.1 THE NEED FOR HOLIDAY DETECTION

Protective coating failure can result in corrosion, or other deterioration, of the underlying material or substrate. Possible problems include the formation of corrosion product such as rust or pits and chemical attack. The resulting repairs of the coating and the inability to use the affected equipment and plant can be very expensive.

Often, failure occurs due to the presence of flaws in the finished coating. Typical flaws are pinholes (a very narrow hole running from the coating surface to the substrate), holidays (small uncoated areas), inclusions (objects trapped in the coating, e.g. grit from blast cleaning), air bubbles, cracks and thin spots. Therefore, it is good practice to inspect a coating for defects and flaws, following established guidelines or procedures.

3.2 HOW YOUR DETECTOR WORKS

The detector generates a high DC voltage that is applied to the coating surface through a probe. In addition, the detector is connected to the substrate via the high voltage return (earth) lead. When the probe is passed over a coating flaw, then the electrical circuit is completed and current flows from the probe to the substrate. As a result, audible and visual alarms are activated in the detector and a spark may be produced at the flaw.

Your Elcometer 236 DC Holiday Detector will detect coating flaws providing the coating is:

- Non-conducting.
- Applied to a conducting substrate (including concrete).
- At least 200 μm (0.008") thick, and preferably over 500 μm (0.020"), thick.

4 STANDARDS AND TEST METHODS

The Elcometer 236 DC Holiday Detector can be used in accordance with the following list of standards and test methods:

Table 1: Standards and test methods

Standard or Method No	Date	Title	Notes
ISO 2746	1994	Vitreous and porcelain enamels - Enamelled articles for service under highly corrosive conditions - High voltage test	Test voltage above 2 kV for enamel thicker than 220 μm
ASTM D 4787	1988	Continuity verification of liquid or sheet linings applied to concrete	High voltage (above 900 V) test. Set voltage below dielectric breakdown strength of lining. Move probe at 0.3 m/s (1 ft/s) max.
ASTM F 423	1975	PTFE plastic-lined ferrous metal pipe and fittings	Electrostatic test: 10 kV, spark at defect is cause for rejection
ASTM G 6	1983	Abrasion resistance of pipeline coatings	Porosity test prior to abrasion testing. Test voltage is calculated as $V = 1250 \cdot \sqrt{\text{Thickness}} \text{ (mil)}$

Table 1: Standards and test methods

Standard or Method No	Date	Title	Notes
ASTM G 62-B	1987	Holiday detection in pipeline coatings	Method B. Thickness <1.016 mm $V = 3294 \cdot \sqrt{\text{Thickness}}$ (mm) Thickness >1.014 mm $V = 7843 \cdot \sqrt{\text{Thickness}}$ (mm)
NACE SP0188	2007	Discontinuity (Holiday) Testing of Protective Coatings	Low and high voltage equipment and tests.
NACE RP0274	1974	High Voltage Electrical Inspection of Pipeline Coatings prior to installation	DC or Pulsed test voltage $V = 1250 \cdot \sqrt{\text{Thickness}}$ (mil)
NACE RP0490	1990	Holiday Detection of Fusion-Bonded Epoxy External Pipeline Coatings of 10-30 mils (0.25mm-0.76mm)	DC in dry conditions. $V = 525 \cdot \sqrt{\text{Thickness}}$ (mil). Trailing ground lead of 9 m allowed if pipe is connected to 2-3ft earth spike and soil is not dry
BS 1344-11	1994	Methods of testing vitreous enamel finishes Part II: High voltage test for articles used under highly corrosive conditions	Same as ISO 2746 (Test voltage above 2 kV for enamel thicker than 220 μm)

Table 1: Standards and test methods

Standard or Method No	Date	Title	Notes
ANSI/AWWA C213-91	1992	Fusion-bonded epoxy coating for the interior and exterior of steel water pipes	$V = 525 \cdot \sqrt{\text{Thickness}} \text{ (mil)}$
ANSI/AWWA C214-89	1990	Tape coating systems for the exterior of steel water pipes	Min. Voltage is 6 kV. Use NACE RP-0274
AS 3894.1	1991	Site testing of protective coatings. Method 1: Non- conductive coatings – Continuity test – High voltage (brush) method	Testing coatings > 150 μm at voltages >500 V $V = 250 \cdot \sqrt{\text{Thickness } (\mu\text{m})} / \text{factor}$
JIS G-3491		Asphalt coatings on water line pipes	Inside walls 8-10 kV Dipped Coatings 6-7 kV Outside walls 10-12 kV
JIS G-3492		Coal-tar enamel coatings on water line pipes	Inside walls 8-10 kV Dipped coatings 6-7 kV Outside walls 10-12 kV Welded areas as inside walls
Note: <i>The above list and comments have been extracted from the documents identified and every effort has been made to ensure the content is correct. No responsibility can be accepted, however, for the accuracy of the information as these documents are updated, corrected and amended regularly. A copy of the relevant standard or method must be obtained from the source to ensure that it is the current document.</i>			

5 GETTING STARTED

5.1 THE CONTROL PANEL

Figure 1. Control Panel Layout

1. LCD - Display of output voltage
2. SENSITIVITY- Sensitivity control for alarm
3. ALARM - Visual alarm (illuminates when flaw detected)
4. ON/TEST
 - ON button position
 - OFF centre position
 - TEST top position (hold down to operate)
5. PROBE VOLTAGE Voltage control (10 turn)
6.  Battery level indicator
7. kV/ μ A - Voltage/Current Switch

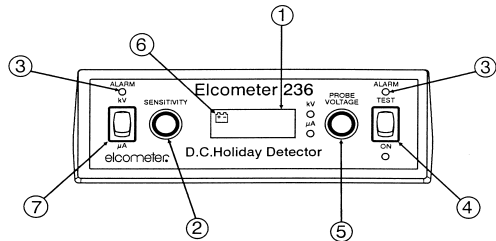

5.2 CONNECTIONS AND TERMINALS

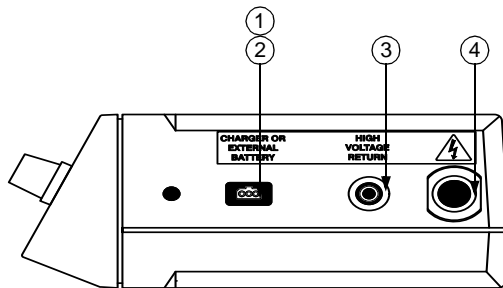

Figure 2. Side connections and terminals layout

1. External battery pack connection
2. Battery charger connection
3. High voltage return (earth lead) terminal
4. High voltage probe connection

5.3 THE PROBE HANDLE

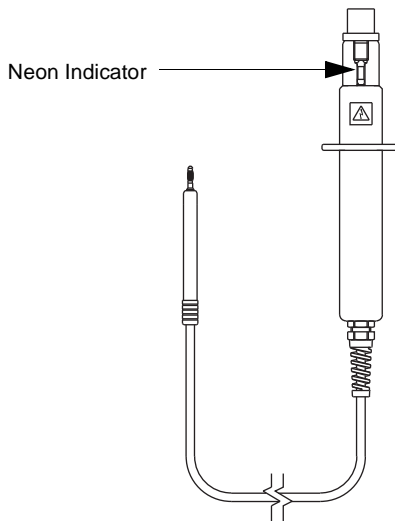

Figure 3. Probe Handle

5.4 THE CARRY CASE

The detector can be used in the carry case or removed from the case for use as appropriate. The carry case can also be used to store and protect the detector when it is being carried to a job.



The carry case has an inner flap that can be held open by means of a Velcro™ strip. The probe handle or other accessories can be attached to the front of the case by means of the two Velcro strips provided. The accessory pouch can be locked on to the side of the case by means of the special T type connector that is inserted and twisted through 90° to lock it in place.

The accessory pouch can be used to carry the battery charger or the extra rechargeable battery as appropriate. In use, the lead from the spare battery to the detector is passed through the loops inside the case outer flap to secure it. This prevents it hanging loose and catching on any item as the user is carrying the detector.

The carry case has a convenient and adjustable shoulder strap for ease of use. In the event that the strap is lost or damaged a replacement is available - see "Spares" on page 37.

The kit is supplied in an outfit case that is also convenient for transportation and long term storage.

5.5 QUICK START GUIDE

ALWAYS read “Working safely” on page 5 before using this equipment.

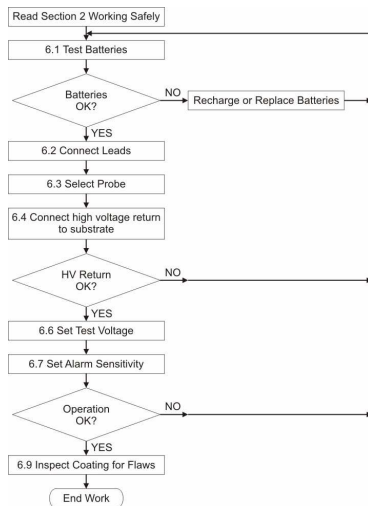

6 USING THE HOLIDAY DETECTOR

ALWAYS read “Working safely” on page 5 before using this equipment.

6.1 TEST BATTERIES

Turn **PROBE VOLTAGE** control fully anti-clockwise to set the voltage output to zero.

Push and hold down **ON/TEST** switch to the **TEST** position. If the battery low indicator  is not shown on the display the instrument is ready for use. Otherwise the battery requires charging - see “Charging the battery” on page 35.

6.2 CONNECT LEADS

Note: *If the detector is being used in the carry case provided, slip the high voltage return (earth) lead through the loop on the side of the case. This will reduce the possibility of the high voltage return (earth) lead becoming detached accidentally.*

Switch **ON/TEST** to the centre position and turn **PROBE VOLTAGE** fully anti-clockwise to ensure that the instrument is safe (minimum output voltage).

Connect the black high voltage probe handle and lead to the high voltage probe connection and the black high voltage return (earth) lead to the High voltage return terminal.

6.3 SELECT PROBE

Select the probe best suited for the work (see “Probe selection” on page 28), and attach it to the high voltage probe.

6.4 CONNECT HIGH VOLTAGE RETURN TO SUBSTRATE

Clamp the high voltage return cable (earth lead) to exposed substrate.

6.5 CHECK OPERATION OF HIGH VOLTAGE RETURN CONNECTION

The instrument has two measurement ranges voltage or current. For the purpose of this test method only the voltage range is of interest. To select the voltage measurement range the range selection switch should be in the kV position.

Holding the probe by its handle and in free air, press **ON/TEST** on the side marked **ON** to turn the detector on.

Turn **PROBE VOLTAGE** clockwise until the LCD display indicates an output of 1 kV and turn **SENSITIVITY** fully clockwise.

Place the probe on bare substrate or the high voltage return (earth) connection.

The audible alarm should sound, **ALARM** should light and the neon indicator in the probe handle should glow, indicating that the high voltage return connection is good.

Switch **ON/TEST** to the centre position. Turn **PROBE VOLTAGE** and **SENSITIVITY** fully anti-clockwise to leave the detector in a safe condition.

If the detector does not respond as described then the high voltage connection is not satisfactory. Repeat all the previous steps and try again. If the high voltage return is still not satisfactory, refer to "Troubleshooting" on page 30. In addition, confirm that the substrate is a conductor and the coating an insulator. If this is not the case, then the detector will not work.

6.6 SET TEST VOLTAGE

For test voltage selection methods, see “Setting the test voltage and sensitivity” on page 22.

Holding the probe in free air press **ON** position to turn the detector on.

Turn **PROBE VOLTAGE** clockwise until the required test voltage is indicated on the LCD display.

6.7 SET ALARM SENSITIVITY

Turn **SENSITIVITY** clockwise to set the sensitivity to a suitable level, see “Setting the test voltage and sensitivity” on page 22 for details on setting sensitivity.

6.8 CHECK FOR CORRECT OPERATION

Either find or make a flaw in the coating. Using the procedure outlined in section 6.9, test that the flaw can be located.

If the flaw is not detected, check that all the preceding steps have been undertaken correctly. If so, then refer to “Troubleshooting” on page 30.

6.9 INSPECT COATING FOR FLAWS

Place the probe on the test surface. Keep the probe in contact with the surface and move it over the work area at a speed of approximately one metre every four seconds, 0.25 m/s (10"/s).

The presence of one or more of the following indicates that there is a flaw in the coating:

- A spark between the probe and the surface
- **ALARM** flashes
- The audible alarm sounds

- The output voltage, indicated on the LCD display, drops substantially
- The probe neon indicator glows

The probe should always touch the surface. Gaps between the probe and the coating can result in genuine flaws not being detected.

6.10 MOVING WORK POSITION AND FINISHING WORK

Prior to repositioning the high voltage return lead, the detector should be switched **off** and the output voltage turned to **zero**.

When the high voltage return (earth lead) has been attached at its new position, the connections should always be checked - see "Check operation of high voltage return connection" on page 17.

Always turn the detector off and set the voltage to zero before disconnecting the leads, when work is finished and when leaving work unattended.

7 STATIC ELECTRICITY

As the probe is moved over the surface of a coating, a static charge builds up which can:

- Cause objects in contact with the surface to become charged with the same polarity.
- Induce an opposite charge on nearby objects electrically insulated from the surface.

The following examples demonstrate the possible effects on the operator if inside a short pipe insulated from the ground:

Operator <i>not wearing</i> rubber gloves or footwear:	Operator <i>wearing</i> rubber gloves and footwear:
The operator is touching the coating.	The rubber gloves and footwear insulate them from the coating.
The body then becomes charged at the same polarity as the coating.	The body becomes charged with the opposite polarity to the coating
No shock if the coating is touched.	If an uninsulated part of the Operator touches the coating, discharge will cause a shock.
The operator gets a shock stepping from the pipe to the ground.	The operator gets a shock stepping from the pipe to the ground

AVOIDING STATIC SHOCK

A conductive strap between the operator and the ground (earth) will stop the body from becoming charged. Rubber gloves and footwear should be worn. There may still be a shock inside the pipe if an un-insulated part of the body touches the charged coating.

In addition to the above methods it is also recommended that the work piece should be bonded to a earth potential thus preventing any build-up of charge, which can remain on a isolated test piece for several minutes after testing has been completed.

8 USING THE CURRENT MONITORING FUNCTION

In addition to being able to monitor the voltage available at the end of the high voltage probe, the instrument is also capable of monitoring the current flowing from the high voltage probe through the work piece and back to the high voltage (earth) return. This facility enables the measurement technique to be used on partially conductive coatings or a method of testing the breakdown voltage of insulating materials, i.e. Testing the breakdown voltage of insulation used in electric blankets.

8.1 BREAKDOWN VOLTAGE OPERATION OUTLINE

ALWAYS consult the safety guide before using equipment.

After preliminary equipment checks, the high voltage return (earth) lead should be connected to the substrate or conductive material that the insulation is bonded to. The test voltage is selected and applied to the coating surface through a probe. If the probe is passed over a coating flaw, then current flows as the electrical circuit is closed. This results in audible and visual alarms being activated in the detector and a spark may be produced between the probe and the substrate.

SETTING THE VOLTAGE

The aim of this test method is to determine the insulation resistance of the non-conductive coating.

As such the voltage should be set to the breakdown or maximum working voltage of the insulating material. Thus by monitoring the current flow during the test it is possible to determine the approximate insulation resistance of the non-conducting material.

SETTING THE ALARM SENSITIVITY

The alarm function for this type of test does not provide any useful information, for this reason the alarm is set to the minimum sensitivity i.e. the **Sensitivity** if fully anti-clockwise.

CURRENT MONITORING RANGE SELECTION

In order to monitor the current flow the measuring range of the instrument must be changed, this is achieved by placing the range selection switch in the μA position.

9 SETTING THE TEST VOLTAGE AND SENSITIVITY

For effective testing, the output voltage must lie between upper and lower limits. The upper voltage limit is that at which the coating itself would breakdown and be damaged. Therefore, the test voltage should be lower than this value. The lower limit is the voltage required to break down the thickness of air equivalent to the coating thickness. If the output voltage is not greater than this value, then a flaw will not be detected. The following describes how the band of safe, but effective, voltage outputs may be determined.

9.1 DIELECTRIC STRENGTH

Whatever the material, if a high enough voltage is applied, it will conduct electricity. However, for insulators, e.g. paint, the level of voltage required to achieve a current flow usually results in irreversible material damage.

The voltage at which a particular thickness of material breaks down is termed the dielectric strength. This is usually expressed as the voltage per unit distance, e.g. kV/mm. Its value depends on the type of applied voltage, e.g. AC, DC or pulsed, temperature and thickness. Figure 4 shows the relationship between breakdown voltage (DC) and thickness for materials of different dielectric strengths.

The upper voltage limit is the dielectric strength of the material multiplied by its thickness and the lower voltage limit is the dielectric strength of air multiplied by the thickness.

The dielectric strength of coating materials usually lies in the region of 10 kV/mm to 30 kV/mm. The dielectric strength of air ranges from 1.3 kV/mm to 4 kV/mm.

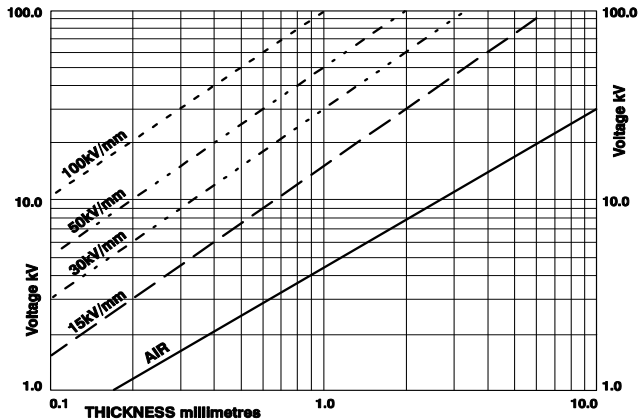

Figure 4. Breakdown voltage against thickness for materials of different dielectric strengths

9.2 ESTABLISHING THE VOLTAGE LIMITS

THE LOWER LIMIT

The lower limit for effective operation is that required to breakdown the thickness of air equivalent to the coating thickness. The breakdown voltage of a given thickness of air varies with humidity, pressure and temperature but is ~ 4 kV/mm (0.1 kV/mil)

If the coating thickness is known, or can be measured, the lower limit value can be read from Figure 4, using the line marked AIR. For instance, if the coating thickness is 1.0 mm then the lower limit is ~ 4.5 kV.

If the coating thickness is not known then the minimum value has to be established experimentally. Turn the output voltage to zero and position the probe over an unprotected area of substrate at the normal height of the coating surface. Turn the voltage up slowly and steadily until a spark is produced and note the voltage. This voltage forms the lower limit.

THE UPPER LIMIT

The upper voltage limit may be determined by:

The job specification - if available and a test voltage is stated.

The dielectric strength - if specified for the applied coating.

Measure the thickness of the layer and refer to Figure 4. Alternatively, calculate the maximum voltage, allowing for variations in the coating thickness. Note that 1 kV per mm is equivalent to 25.4 V per mil (thou).

Note: *This method is only suitable if the dielectric strength values were determined for a DC voltage.*

Experiment - Touch the probe on an unimportant area of the work piece. Increase the voltage slowly and steadily until a spark passes through the coating and note the voltage. The dielectric strength can be calculated by dividing this voltage by the coating thickness.

Tables and formulae - from established Codes of Practice, e.g. NACE and ASTM. See Table 2, Table 3 and Table 4.

9.3 SETTING THE TEST VOLTAGE

Once the voltage limits have been established, set the output voltage approximately halfway between the two values.

9.4 SETTING ALARM SENSITIVITY

Alarm sensitivity is the current threshold or level, above which the alarm triggers when a flaw is detected. It is adjustable so that the effects of any prevailing electrical leakage, through the coating or moist air, can be counteracted to prevent false alarms.

Turning the **SENSITIVITY** knob clockwise, decreases the current threshold and makes the detector more sensitive. **SENSITIVITY** turned fully clockwise gives the maximum detector sensitivity and the lowest threshold current. **SENSITIVITY** turned fully anti-clockwise gives the minimum detector sensitivity and the highest threshold current.

If the sensitivity is too high, the alarm will operate when current flows in the absence of a fault, e.g. due to damp surfaces or slightly conductive coatings.

If sensitivity is too low then the alarm will not be triggered, as the current will never reach the threshold level. However, the probe handle neon indicator will still illuminate and sparking may occur when a flaw is detected.

Table 2: kV values from ASTM G62-87 (up to 1 mm)

Microns	Kilovolts (kV)	Thou	Kilovolts (kV)
100	1.04	5	1.17
200	1.47	10	1.66
300	1.80	15	2.03
400	2.08	20	2.34
500	2.33	25	2.63
600	2.55	30	2.88
700	2.76	35	3.11
800	2.95	40	3.32
900	3.12		
1000	3.29		

Table 3: kV values from ASTM G62-87 (above 1 mm)

mm	Kilovolts (kv)	Thou	Kilovolts (kV)
1	7.84	40	7.91
2	11.09	80	11.18
3	13.58	120	13.69
4	15.69	160	15.81
5	17.54	200	17.68
6	19.21	240	19.36
7	20.75	280	20.92

Table 4: kV values from NACE RP0188-88

mm	Thou	Kilovolts (kV)
0.20 to 0.28	8 – 11	1.5
0.30 to 0.38	12 – 15	2.0
0.40 to 0.50	16 – 20	2.5
0.53 to 1.00	21 – 40	3.0
1.01 to 1.39	41 – 55	4.0
1.42 to 2.00	56 – 80	6.0
2.06 to 3.18	81 – 125	10.0
3.20 to 3.43	126 – 135	15.0

10 PROBE SELECTION

Table 5 shows the most suitable probe to use depending on the characteristics of the surface to be tested, e.g. internal and external pipe surfaces, large surfaces and complex shapes. In addition, long reach applications can be carried out using extension pieces that are suitable for use with all probe types. The extension pieces are available in 250 mm, 500 mm and 1000 mm lengths. Joining the extension pieces with a coupling can make up other lengths.

All probes, extensions and couplings mentioned in this Section are available from Elcometer or your local Elcometer supplier. Only those fittings supplied by Elcometer should be used with this detector.

Further details of the probes and other accessories, including part numbers, are given in "Spares" on page 37.

Table 5: The best probe for various surface types

Type of Surface	Recommended Probe	Notes
Small area, complex surface, general application	Band brush probe	Provides low contact pressure
Large surface areas	Right-angle brush probe	Available in different widths, with conductive strip for light contact and phosphor bronze wire for medium contact

Table 5: The best probe for various surface types

Type of Surface	Recommended Probe	Notes
Insides of pipes 40 mm to 300 mm (1.5" to 12") diameter	Circular brush probe	Includes 250 mm extension rod
Outside of pipes, 50 mm to 1000 mm (2" to 36") diameter	Rolling spring probe	A phosphor bronze spring with a 250 mm extension rod supplied as standard

11 TROUBLESHOOTING

11.1 LCD DISPLAY RELATED PROBLEMS

LCD DISPLAY DOES NOT FUNCTION

Possible Reason	Solution
The detector is not set to ON position	Switch ON/TEST to ON
The battery is flat, as indicated by the low battery indicator on the LCD	Recharge the battery, see section 12.1

LCD DISPLAY SHOWS -1 CONTINUOUSLY

Possible Reason	Solution
Voltage higher than range of LCD	Decrease the output voltage or use a larger capacity detector

DISPLAYED VOLTAGE DROPS DURING TEST

Possible Reason	Solution
Conductive surface, Probe surface area too large	See section 11.4. Use a smaller probe (see section 10) or increase the output voltage

DISPLAYED VOLTAGE IS HIGHER THAN THAT AT PROBE TIP

Possible Reason	Solution
Damaged high voltage lead	Replace lead
Missing or broken neon indicator	Replace Neon indicator
Poor high voltage return connection	Check all connections, see section 6.2

11.2 ALARM RELATED PROBLEMS

CONTINUOUS ALARM SOUNDING

Possible Reason	Solution
Conductive coating	See "Conductive coatings" on page 32
Sensitivity too high	Reduce sensitivity by turning SENSITIVITY anti-clockwise
Probe movement too fast	Move at 0.25 m/s (10"/s)
Probe surface area too great	Use smaller probe, see section 10

NO ALARM WHEN A FAULT IS DETECTED

Possible Reason	Solution
Sensitivity too low	Increase sensitivity by turning SENSITIVITY clockwise.
Voltage too low	Increase voltage by turning PROBE VOLTAGE clockwise. Also see section 9

11.3 NO SPARK AT PROBE TIP

Possible Reason	Solution
Neon indicator in handle	Replace neon indicator damaged
Damaged leads	Repair or replace leads
Poor connections	Clean connections and reconnect leads, see section 6.2
Flat battery	Recharge battery, see section 12.1

11.4 SPECIAL CONSIDERATIONS

CONDUCTIVE COATINGS

As stated above, if the displayed voltage drops sharply when the probe is applied to the test surface or the alarm sounds continuously, then the coating may be conductive. The usual occurrences of conductive coatings are described in the following.

EXISTENCE OF METALLIC, CARBON OR OTHER CONDUCTING PARTICLES IN THE COATING: During normal use, the particles in this type of coating are not linked. However, when the coating is subjected to high voltages the material between the particles can break down. This results in the coating becoming conductive and the detector indicating the presence of a flaw.

To overcome this effect, the voltage should be reduced so that it is still high enough to detect flaws but low enough to avoid break down of the coating. However, in some cases the coating will still conduct at voltages that are too low to locate a flaw. In this case, the holiday detector is not a suitable method for checking the coating.

SURFACE MOISTURE OR CONTAMINATION: Certain soluble salts attract moisture from the atmosphere and this and other forms of surface contamination can form a path across the surface to the high voltage that is not due to a coating flaw. Under these conditions the detector indicates non-existent flaws. When these circumstances occur, the surface should either be dried using a suitable cloth or cleaned with a non-conducting cleaner or solvent which will not damage the coating.

Note: *Ensure that any cleaner or solvent containers are removed from the test area before re-commencing the test.*

MOISTURE PENETRATION OR ABSORPTION: Moisture can enter materials, e.g. glass reinforced plastic along the reinforcing glass fibres, if the surface is eroded or scratched and then immersed in water. In this case, allow adequate time for the coating to dry prior to testing.

RUBBER LININGS: These may be slightly conductive due to their carbon content. As with other conductive coatings, reduce the alarm sensitivity so that the detector indicates a known flaw but does not sound when the probe is placed on sound coating. It may also be necessary to increase the test voltage to compensate for the current flow through the coating.

COATING MAY NOT BE FULLY CURED: In this case the coating still contains solvents which allow the path to the high voltage to be formed even if a flaw is not present. To overcome this problem, allow the coating to cure before undertaking the test.

CONCRETE SUBSTRATES

If a concrete or cement substrate contains enough moisture, then it will conduct electricity and the holiday detector can be used to detect flaws in its coating.

The procedure is generally the same as that described in “Using the Holiday Detector” on page 16, but the following points should be noted. Hammering a masonry nail, or similar conducting spike, into the concrete or cement makes the high voltage return contact.

The suitability of the concrete for use with a holiday detector can be checked using the following. Make a high voltage return contact by hammering a nail or similar into the concrete. Attach the high voltage return lead to the nail and set test voltage for the thickness of coating, or in the range 3 kV - 6 kV if the test voltage is not known.

Place the probe on uncoated concrete about 4 metres (13 feet) from the nail. If the alarm sounds, then the concrete is sufficiently conductive.

If the concrete is too dry, i.e. the alarm does not sound, then it is unlikely that the holiday detector will be a suitable inspection method.

LENGTHENING THE HIGH VOLTAGE RETURN (EARTH) LEAD

If the high voltage return connection is at some distance from the test area then a longer high voltage return lead should be used- see “Other accessories” on page 44.

This ensures that the detector, and therefore alarms, will be close to the operator and that the voltage decrease in the probe lead will be not be too high.

Note: *In order to comply with the EMC directive only earth return lead lengths specified by the manufacturer should be utilised. Increasing the length of the lead beyond the maximum length (10 m) may lead to the unit being susceptible to radio frequency interference. Likewise if a large test piece is being inspected a similar effect may be observed. If in doubt consult Elcometer or your local Elcometer Supplier.*

12 MAINTENANCE

Your Holiday Detector is designed to give many years reliable service under normal operating and storage conditions.

The Elcometer 236 DC Holiday Detector does not contain any user-serviceable components. In the unlikely event of a fault, return your Detector to Elcometer or your local Elcometer Supplier. The warranty will be invalidated if the instrument has been opened.

Details of Elcometer offices around the world are given on the outside cover of these Operating Instructions. Alternatively visit the Elcometer website, www.elcometer.com

12.1 BATTERY MAINTENANCE

The Elcometer 236 is designed to operate from an internal power source consisting of a nickel metal hydride battery. As such, there is no battery maintenance required.

For safety and reliability, the battery is dispatched from Elcometer in an uncharged state and must be charged before use.

The battery life for the 30 kV unit is typically greater than 10 hours depending on the working voltage and number of faults found during the working day. The 15 kV unit battery life is greater than 20 hours. Recharging the battery will take approximately 12 hours and should only be attempted with the charger supplied with the instrument.

An external battery can be connected to the unit, bypassing the internal battery. This will give continuous operation exceeding 10 or 20 hours if required - see "Other accessories" on page 44 for ordering details.

CHARGING THE BATTERY

Charging of the battery is not required until the battery low level symbol lights on the display. Once this symbol shows, there should be approximately half an hour of battery life before the performance of the instrument will suffer.

Charging of internal or external batteries should only be attempted with the charger supplied. When the battery low  indicator shows in the display, the instrument should be turned off and if an external battery is being used this should be unplugged from the instrument and then recharged.

The charger should then be plugged into the appropriate socket on the instrument or external battery pack and the mains power switched on. A red light on the charger shows that the battery is charging correctly. In the event that the light does not come on, return to Elcometer or your local Elcometer Supplier for repair.

After 12 hours the battery will be fully charged, at this time the red light on the charger unit will flash on a regular basis.



WARNING: *No attempt should be made to use the instrument whilst the battery is charging, doing so may result in permanent damage to the charger and or the instrument itself.*

12.2 ROUTINE CHECKS

Check the detector, probe and high voltage return leads and connectors for damage at regular intervals. Replace any parts that are worn or are of doubtful condition. See “Spares” on page 37 for replacement parts.

If the detector is not being used regularly, check that the indicators and monitors are all in working order (See section 6.1 to section 6.5) and recharge the battery as necessary (See section 12.1).

Certificates of Calibration can be issued at the time of purchase. If a Certificate of Calibration is required, return the detector to Elcometer or your local Elcometer Supplier, for retest and certification. Renewal of the Certificate is recommended on an annual basis.

13 STORAGE



The Elcometer 236 DC Holiday Detector incorporates a Liquid Crystal Display. If the display is heated above 50°C (120°F) it may be damaged. This can happen if the conductivity meter is left in a car parked in strong sunlight.

Always store the components of the Elcometer 236 DC Holiday Detector in the carrying case when the Detector is not being used.

14 SPARES

See also "Probe selection" on page 28 for information on probes.

14.1 RIGHT ANGLE PROBES

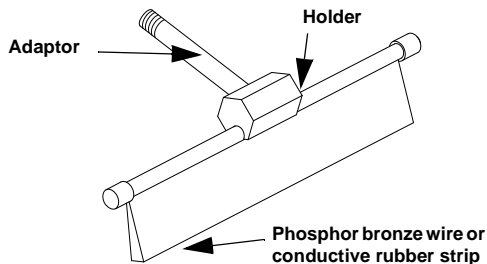

Right angle probes are most suitable for large, relatively flat, surface areas. They are available in 3 widths and include a probe holder and a 100 mm adaptor as standard.

The adaptor on this probe cannot be replaced by an extension piece. Extension pieces can be added using a coupling (see section 14.4).

Width	Brush	Rubber Strip
250 mm	T23638071	T23638081
500 mm	T23638072	T23638082
1000 mm	T23638073	T23638083
1400 mm	–	T23638084

SPARE ELECTRODES FOR RIGHT ANGLE PROBES

Width	Brush	Rubber Strip
250 mm	T99926621	T99926731
500 mm	T99926622	T99926732
1000 mm	T99926623	T99926733
1400 mm	—	T99926734

14.2 CIRCULAR BRUSH PROBES

Circular brush probes are used to test internal pipe surfaces.

They are available in 12 sizes and include an adaptor and a 250 mm extension piece as standard.

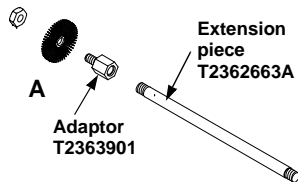
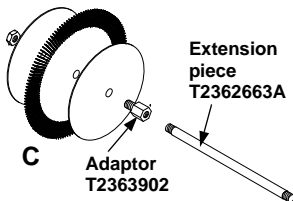
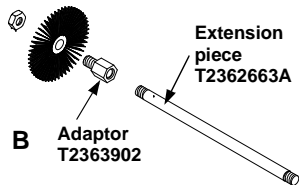

Pipe Diameter mm (ins)	Assy. Part Numbers	Spare Brush Part Numbers	Figure
38 (1.5)	T2363907A	T9993766-	A
51 (2.0)	T2363907B	T9993767-	A
64 (2.5)	T2363907C	T9993768-	B
76 (3.0)	T2363907D	T9993769-	B
89 (3.5)	T2363907E	T9993770-	B
102 (4.0)	T2363907F	T9993771-	B
114 (4.5)	T2363907G	T9993772-	B
127 (5.0)	T2363907H	T9993773-	B
152 (6.0)	T2363907I	T9993774-	B
203 (8.0)	T2363907J	T9993775-	C
254 (10.0)	T2363907K	T9993776-	C
305 (12.0)	T2363907L	T9993777-	C

Note: For larger diameters use a right angle brush probe.

14.3 ROLLING SPRING PROBES

Rolling spring probes are used to test external pipe surfaces.

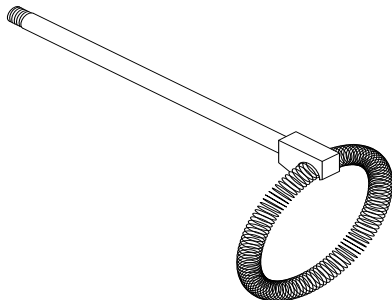

Description	Part Number	
Elcometer 236 Rolling Spring Holder	T23620507	
Select the required spring size from the list below		
Rolling Spring Probe: OD 48-54mm; NPS 1.5; DN 40	T99920438-15A	
Rolling Spring Probe: OD 54-60mm; NPS 1.5; DN 40	T99920438-15B	
Rolling Spring Probe: OD 60-65mm; NPS 2; DN 50	T99920438-20A	
Rolling Spring Probe: OD 66-73mm; NPS 2; DN 50	T99920438-20B	
Rolling Spring Probe: OD 73-80mm; NPS 2.5; DN 65	T99920438-25A	
Rolling Spring Probe: OD 80-88mm; NPS 2.5; DN 65	T99920438-25B	

Description	Part Number
Rolling Spring Probe: OD 88-95mm; NPS 3; DN 80	T99920438-30A
Rolling Spring Probe: OD 95-100mm; NPS 3; DN 80	T99920438-30B
Rolling Spring Probe: OD 100-108mm; NPS 3.5; DN 90	T99920438-35A
Rolling Spring Probe: OD 108-114mm; NPS 3.5; DN 90	T99920438-35B
Rolling Spring Probe: OD 114-125mm; NPS 4; DN 100	T99920438-40A
Rolling Spring Probe: OD 125-136mm; NPS 4.5; DN 114	T99920438-45A
Rolling Spring Probe: OD 136-141mm; NPS 4.5; DN 114	T99920438-45B
Rolling Spring Probe: OD 141-155mm; NPS 5; DN 125	T99920438-50A
Rolling Spring Probe: OD 155-168mm; NPS 5; DN 125	T99920438-50B
Rolling Spring Probe: OD 168-180mm; NPS 6; DN 152	T99920438-60A
Rolling Spring Probe: OD 180-193mm; NPS 6; DN 152	T99920438-60B
Rolling Spring Probe: OD 193-213mm; NPS 7; DN 178	T99920438-70A
Rolling Spring Probe: OD 213-219mm; NPS 7; DN 178	T99920438-70B
Rolling Spring Probe: OD 219-240mm; NPS 8; DN 203	T99920438-80A
Rolling Spring Probe: OD 240-264mm; NPS 9; DN 229	T99920438-90A
Rolling Spring Probe: OD 264-290mm; NPS 10; DN 254	T99920438-100A
Rolling Spring Probe: OD 290-320mm; NPS 11; DN 279	T99920438-110A
Rolling Spring Probe: OD 320-350mm; NPS 12; DN 305	T99920438-120A
Rolling Spring Probe: OD 350-375mm; NPS 14; DN 356	T99920438-140A

Description	Part Number
Rolling Spring Probe: OD 375-400mm; NPS 14; DN 356	T99920438-140B
Rolling Spring Probe: OD 400-435mm; NPS 16; DN 406	T99920438-160A
Rolling Spring Probe: OD 435-450mm; NPS 16; DN 406	T99920438-160B
Rolling Spring Probe: OD 450-500mm; NPS 18; DN 457	T99920438-180A
Rolling Spring Probe: OD 500-550mm; NPS 20; DN 508	T99920438-200A
Rolling Spring Probe: OD 550-600mm; NPS 22; DN 559	T99920438-220A
Rolling Spring Probe: OD 600-650mm; NPS 24; DN 610	T99920438-240A
Rolling Spring Probe: OD 650-700mm; NPS 26; DN 660	T99920438-260A
Rolling Spring Probe: OD 700-750mm; NPS 28; DN 711	T99920438-280A
Rolling Spring Probe: OD 750-810mm; NPS 30; DN 762	T99920438-300A
Rolling Spring Probe: OD 810-860mm; NPS 32; DN 813	T99920438-320A
Rolling Spring Probe: OD 860-910mm; NPS 34; DN 864	T99920438-340A
Rolling Spring Probe: OD 910-960mm; NPS 36; DN 914	T99920438-360A
Rolling Spring Probe: OD 960-1010mm; NPS 38; DN 965	T99920438-380A
Rolling Spring Probe: OD 1010-1060mm; NPS 40; DN 1016	T99920438-400A
Rolling Spring Probe: OD 1060-1110mm; NPS 42; DN 1067	T99920438-420A
Rolling Spring Probe: OD 1110-1160mm; NPS 44; DN 1118	T99920438-440A
Rolling Spring Probe: OD 1160-1210mm; NPS 46; DN 1168	T99920438-460A
Rolling Spring Probe: OD 1210-1270mm; NPS 48; DN 1219	T99920438-480A

Description	Part Number
Rolling Spring Probe: OD 1270-1320mm; NPS 50; DN 1270	T99920438-500A
Rolling Spring Probe: OD 1320-1370mm; NPS 52; DN 1321	T99920438-520A
Rolling Spring Probe: OD 1370-1425mm; NPS 54; DN 1372	T99920438-540A

14.4 EXTENSION PIECES

Extension pieces allow the reach of all probes to be increased. Each one requires a coupling piece.

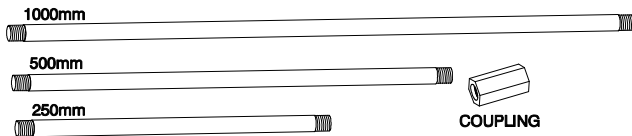

Length	Part Number
250mm	T2362663A
500mm	T2362663B
1000mm	T2362663C
Coupling Piece	T2362666-

An insulated probe extension assembly is also available for use with brush probes. This probe extends from 800 mm to 1250 mm (31.5" to 49") and has 2 m (6' 6") of cable. Sales Part Number is T23615597

14.5 OTHER ACCESSORIES

Band Brush Probe	T2362669-
Battery Pack	T23615550
Battery Charger (UK)	T23613907
Battery Charger (European)	T23613908
Battery Charger (110 V AC)	T23613909
Carry Case	T23613541
Spare Strap for Carry Case	T23613816
Outfit Case	T23615544
High Voltage Return Lead, 2m	T236139031
High Voltage Return Lead, 10m	T236139032
Probe Handle and Lead	T23612700
Spare Neon for Probe Handle	T2361526-

15 TECHNICAL SPECIFICATION

Output voltage:	0.5 kV to 15 kV adjustable 0.5 kV to 30 kV adjustable
Accuracy of voltage setting:	$\pm 5\%$ or ± 0.2 kV
Display resolution:	15 kV: 0.01 kV 30 kV: 0.1 kV
Output current:	0.5 mA maximum
Power supply:	Internal rechargeable battery (nickel metal hydride type) External rechargeable battery available as accessory.
Battery charger units:	12 V output 400 mA for 4 Ah to 5 Ah battery, 12 hours for full charge, BS plug, Euro plug or US (110 V) plug versions
Battery life (depends on voltage setting and number of faults detected):	15 kV version >20 hours 30 kV version >10 hours
Dimensions:	W200mm x L170mm x D70mm (W8" x L7" x D3")
Probe lead length:	2 m (6' 6") to end of probe handle
Earth lead length:	10 m (32' 6")
Weight:	2.8 kg (6 lb 3oz) including carry case and band brush probe

Holiday alarm indications:

Visual

- neon in probe handle.
- indicator on instrument front panel.

Audible

Digital display

LCD, 12.5 mm (0.5") digit height

The instrument is packed in a cardboard and foam package. Please ensure that this packaging is disposed of in an environmentally sensitive manner. Consult your local Environmental Authority for further guidance.

16 RELATED EQUIPMENT

In addition to the Elcometer 236 DC Holiday Detector, Elcometer produces a wide range of other equipment for testing and measuring the characteristics of coatings. Users of the Elcometer 236 DC Holiday Detector may also benefit from the following Elcometer products:

- Elcometer 266 DC Holiday Detector
- Elcometer 270 Pinhole Detector
- Elcometer Inspection Kits
- Elcometer Inspection Manuals

For further information contact Elcometer, your local supplier or visit www.elcometer.com