

# PicoSource<sup>®</sup> PG900 Series

USB differential pulse generators



### Three PicoSource models

Integrated 60 ps pulse outputs: PG911

Tunnel diode 40 ps pulse heads: PG912

Both output types: PG914

### Integrated pulse outputs

Differential with deskew

60 ps transition time

2.5 V to 6 V amplitude

### Tunnel diode pulse heads

Differential with deskew

40 ps transition time

200 mV amplitude

### Advanced features

Output deskew with 1 ps resolution

Low-jitter trigger input and output

User-variable pulse width

Internal trigger clock

Trigger hold-off

### Configuration

USB 2.0 connected

Microsoft Windows compatible

### Applications

TDR/TDT network and match analysis

Spectral and flatness measurements

Timing, jitter, and crosstalk determination

Semiconductor testing

Impulse ultra-wideband radars

Laser diode drivers

## PicoSource® PG900 Series

### USB differential pulse generators

The fast-transition pulse can stimulate a transmission path, device, or network with a broad-spectrum signal in a single instant. These signals, combined with differential capability, are valuable for making high-speed broadband measurements in many fields such as time domain reflectometry, semiconductor testing, gigabit interconnect and port testing, and in radar systems.

High-speed differential data is becoming the dominant measurement challenge in digital, computing, interconnect and telecommunications systems. Despite this need, cost-effective, fast-transition differential pulse generators were hard to find ... until now.



### A versatile, portable pulse generator

The PicoSource PG900 Series of low-jitter triggered differential USB pulse generators offer a range of advanced features:

- The pulse outputs are optimized for broad spectral content (fastest transition time) to best suit spectral and time-domain transmission and reflectometry measurements
- The internal clock provides stand-alone, self-triggered operation
- Trigger input and output allow the pulse generators to source or respond to system triggers
- Differential outputs ensure that the proliferation of gigabit differential interconnects and systems (such as SATA, USB3, HDMI, Ethernet) can all be addressed

Essential to any differential measurement is the ability to adjust for small but significant velocity and path length differences that are bound to exist in any measurement setup. The PicoSource PG900 pulse generator outputs can each be adjusted (time-skewed) by 1 ns (integrated pulse outputs) or 200 ps (tunnel diode pulse heads) in 1 ps increments to deskew path differences before the measurement, or to deliberately stress a transmission path with timing skew.

Despite their small size and portability, PicoSource pulse generators have plenty of drive capability, with integrated step recovery diode outputs of up to 6 V pk each into 50  $\Omega$ . That's a powerful 12 V pk differential pulse amplitude to drive lossy paths or stress system ports. Outputs are adjustable in 10 mV steps down to 2.5 V pk. An adjustable amplitude limit is provided to protect sensitive devices, and 20 dB attenuators are supplied fitted to the pulse outputs for small-signal optimal match applications.

### Key specifications

#### PicoSource PG911 and PG914

- Integrated 50  $\Omega$  SMA(f) step recovery diode outputs
- < 60 ps single-ended pulse transition time
- Two 2.5 V to 6 V variable amplitude outputs
- $\pm 1$  ns timing deskew in 1 ps steps
- 20 dB 10 GHz SMA(m-f) attenuators supplied fitted to SRD pulse outputs

#### PicoSource PG912 and PG914

- External 50  $\Omega$  N(m) positive and negative tunnel diode pulse heads
- < 40 ps pulse transition time
- Fixed 200 mV output amplitude
- $\pm 500$  ps timing deskew in 1 ps steps
- Inter-series N(f)–SMA(m) adaptors included with pulse heads

#### All PicoSource PG900 models

- Differential outputs
- 200 ns to 4  $\mu$ s pulse width
- Adjustable 1  $\mu$ s to 1 s internal clock period
- Typical 3.0 ps RMS jitter relative to external trigger

## Step recovery diode variable-amplitude pulse

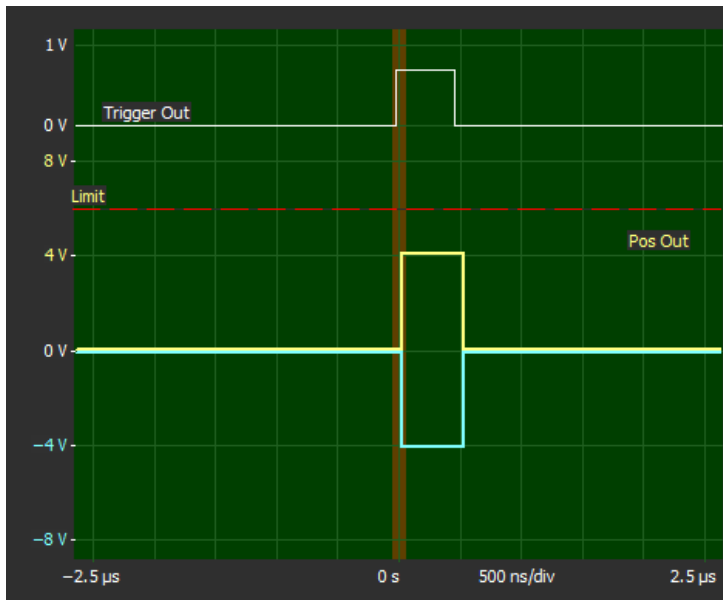

The positive (fast rise) and negative (fast fall) pulses are both ground-referenced and each pulses in opposite polarity to its selected amplitude. This amplitude (the “mark”) is held for the selected pulse width and then returns to ground. Further pulses are prevented for the selected hold-off period and thereafter repeat at 40 ns after the next received trigger. When the internal clock is selected, the pulse repeats at the selected period and hold-off is inactive. An output trigger is generated 40 ns before every pulse, however initiated.

Pulse transition time is typically 55 ps and spectral content extends to 12 GHz.

The negative (fast fall) pulse can be selected for even faster transition time by selecting “fast” rather than “smooth” mode. Pulse aberration is compromised but transition time is typically 45 ps and spectral content extends to around 14 GHz.

## Tunnel diode head fixed-amplitude pulse

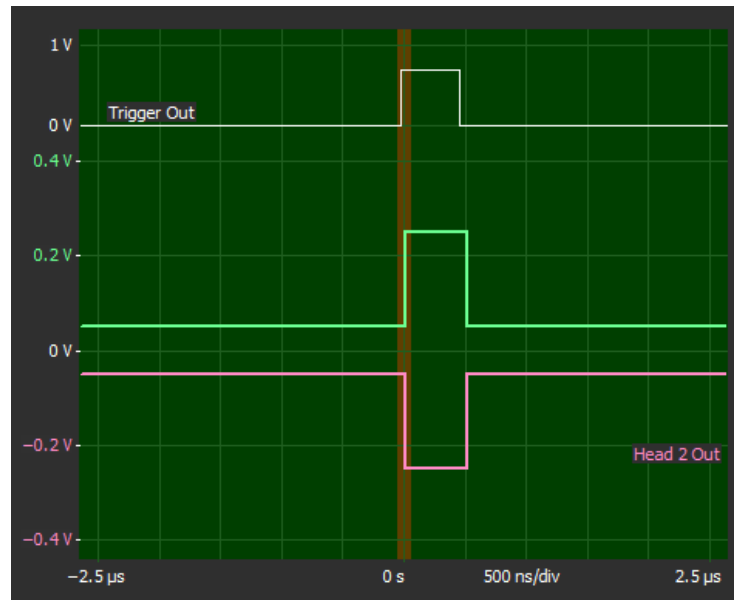

The positive (fast rise) and negative (fast fall) pulses are both DC offset referenced and each pulses in opposite polarity by its independent fixed amplitude. This amplitude (the “mark”) is held for the selected pulse width and then returns to ground. Further pulses are prevented for the selected hold-off period and thereafter repeat at 40 ns after the next received trigger. When the internal clock is selected, the pulse repeats at the selected period and hold-off is inactive. An output trigger is generated 40 ns before every pulse, however initiated.

Pulse transition time is typically 40 ps and spectral content extends to 14 GHz.

Typical pulse shapes are shown below:

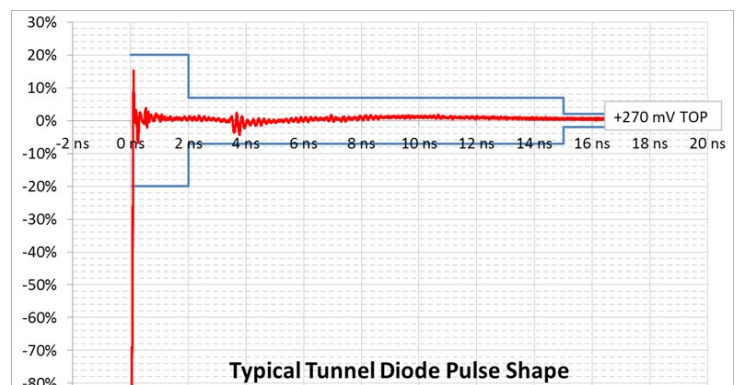
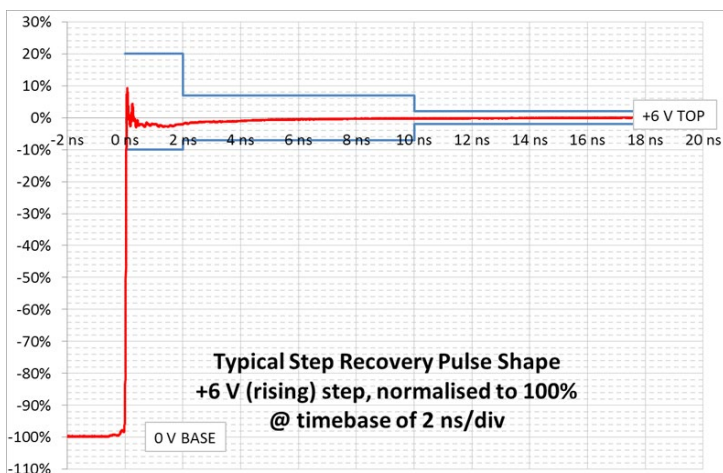

## Connection diagrams

The following diagrams demonstrate differential and single-ended TDR and TDT setup options for a PicoSource pulse generator, PicoScope 9300 Series sampling oscilloscope, and the device under test (DUT). In all setups shown, the PG911 or PG912 pulse generator can be replaced by a PicoSource PG914.

### TDR applications

PicoSource pulse generators can be used to realize time domain reflectometry with a PicoScope 9300 Series sampling oscilloscope without that function (PicoScope 9301, 9302, 9321 and 9341).

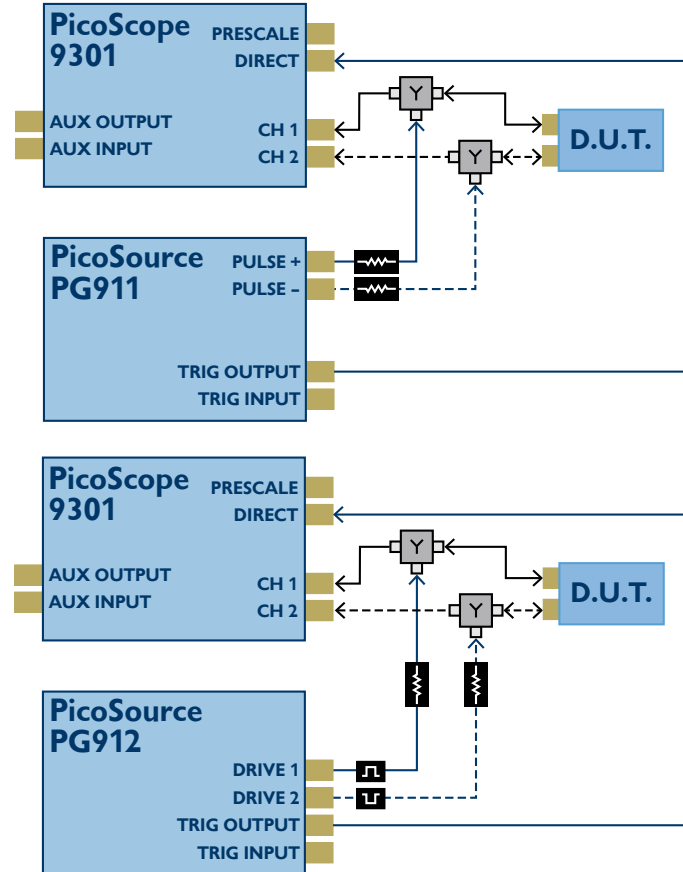

### TDT applications

PicoSource pulse generators can also be used to realize time domain transmission (TDT) with a PicoScope 9300 sampling oscilloscope without that function (PicoScope 9301, 9302, 9321, and 9341). They also offer the versatility of a remotely-placed signal generator for long line or installed system testing when used with any of the PicoScope 9300 models.

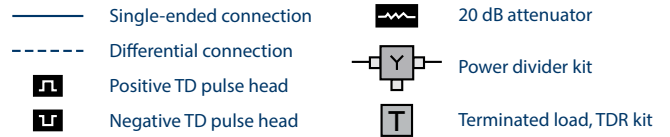
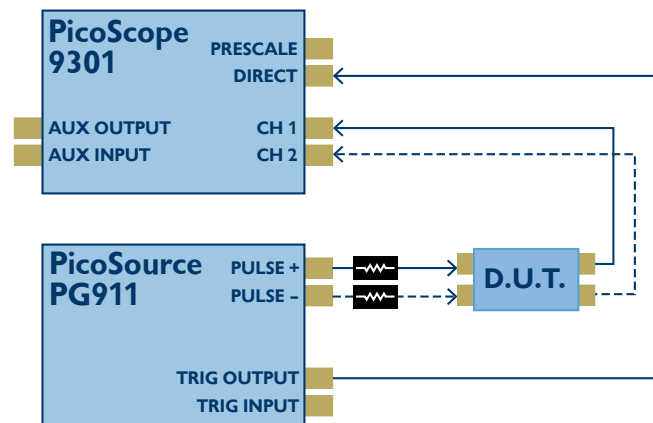

### TDT and crosstalk application

PicoSource pulse generators can be used with a PicoScope 9341 four-channel sampling oscilloscope for simultaneous time domain transmission and crosstalk assessment.

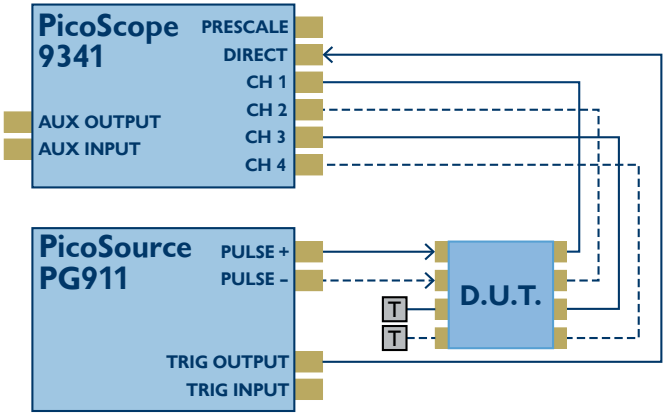

### Single-ended measurements

Single-ended measurements can be performed with a two-channel sampling oscilloscope. Differential measurements can also be tackled by first measuring transmission and then changing connections for crosstalk measurement. Unconnected ports should be correctly terminated in this case.

### PicoSource PG900 pulse control software for Windows

PicoSource pulse generators are connected by USB, and controlled by the supplied PicoSource PG900 software. This straightforward application runs on Microsoft Windows and features a clear graphical display of the pulse, limits and trigger settings as they are applied. Default and user pulse settings can be saved for future use, and the software can be tested in demonstration mode.

PicoSource PG900 software can be downloaded from [www.picotech.com](http://www.picotech.com).

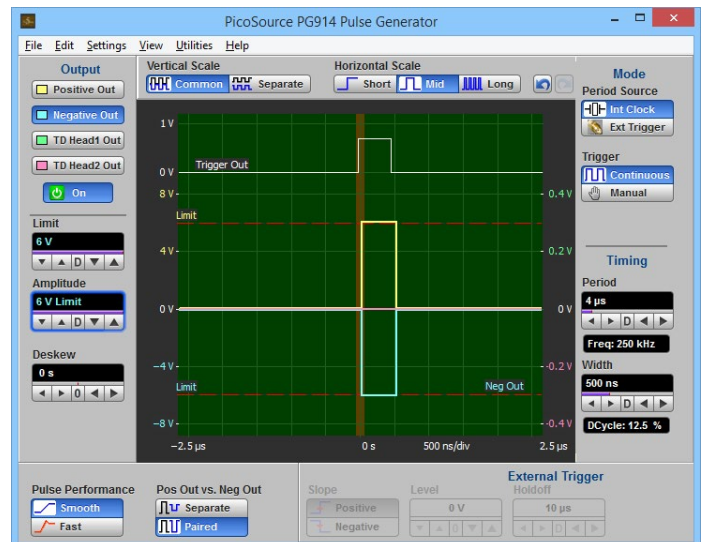

# PicoSource® PG900 Series pulse generator specifications

## PICOSOURCE PG911 AND PG914

### INTEGRATED STEP RECOVERY DIODE PULSE OUTPUTS

|                               |  |  |
|-------------------------------|--|--|
| Pulse outputs                 | Positive-going (fast rise) and negative-going (fast fall) outputs returning to 0 V. Adjustable amplitude and timing parameters. Fast transition on leading edge. |  |
| Output impedance              | 50 Ω   |  |
| Output connector              | SMA(f)   |  |
| Output amplitude              | Adjustable 2.5 V to 6 V in 10 mV steps   |  |
| Output accuracy               | ±10%   |  |
| Output amplitude limit        | 2.5 V to 6 V, adjustable in 100 mV increments  |  |
| Duty cycle limit              | 50% maximum (for 2.5 V to 4 V amplitude)<br>20% maximum (up to 6 V amplitude)  |  |
| Differential deskew range     | Adjustable in 1 ps steps over 2 ns range   |  |
| Pulse transition time         | <b>Positive or negative-going, smooth mode</b><br>< 60 ps (10% to 90%)<br>< +20%, -10% for first 2 ns  | <b>Negative-going, fast mode</b><br>< 50 ps (10% to 90%)<br>< +40%, -10% |
| Pulse aberrations             | < ±7% to 10 ns<br>< ±2% to (pulse width - 50 ns)   |  |
| Trailing edge transition time | < 8 ns (10% to 90%)  |  |

## PICOSOURCE PG912 AND PG914

### DRIVE OUTPUTS WITH TUNNEL DIODE PULSE HEADS

|                                  |   |
|----------------------------------|---|
| Positive tunnel diode pulse head | Positive-going (fast rise) output on < 70 mV pedestal. Fixed amplitude and adjustable timing parameters. Fast transition on leading edge.           |
| Negative tunnel diode pulse head | Negative going (fast fall) output on < -70 mV pedestal. Fixed amplitude and adjustable variable timing parameters. Fast transition on leading edge. |
| Output impedance                 | 50 Ω, ±2 Ω  |
| Output connector                 | N(m)  |
| Output amplitude                 | Fixed 200 mV  |
| Output accuracy                  | ±25%  |
| Differential deskew range        | Adjustable in 1 ps steps over 200 ps minimum, 300 ps typical  |
| Pulse transition time            | < 40 ps (10 % to 90%)<br>< ±20%, for first 2 ns   |
| Pulse aberrations                | < ±7% to 15 ns<br>< ±2% to (pulse width - 50 ns)  |
| Trailing edge transition time    | < 8 ns (10% to 90%)   |
| Dimensions (each pulse head)     | 80 mm x 28 mm x 25 mm   |
| Weight (each pulse head)         | 125 g   |

## ALL MODELS AND OUTPUTS

### PULSE TIMING

|  |   |
|--|---|
| Pulse trigger source                     | External input, manual single shot event or internal clock                              |
| Jitter relative to leading edge          | 3.0 ps RMS typical. 3.5 ps RMS maximum.   |
| Post-trigger delay to pulse leading edge | Fixed 42 ns ±2 ns<br>Allows leading-edge capture on sampling oscilloscopes              |
| Pulse width and accuracy                 | 200 ns to 4 μs ±10% ±50 ns, adjustable in steps of 25 ns                                |
| Pulse width jitter                       | < 150 ppm of width RMS  |
| External trigger hold-off                | Adjustable 1 μs to 1.3 ms in steps of 200 ns, to maximum of 345 ms in steps of < 15 ppm |

### INTERNAL CLOCK SPECIFICATION

# PicoSource® PG900 Series pulse generator specifications continued

|  |   |
|--|---|
| Period and accuracy                          | Adjustable 1 $\mu$ s to 1 s, $\pm 100$ ppm $\pm 10$ ns in steps of 200 ns                           |
| <b>EXTERNAL TRIGGER INPUT SPECIFICATION</b>  |   |
| Impedance                                    | 50 $\Omega$ $\pm 1\%$   |
| Connector                                    | SMA(f)  |
| Maximum input level                          | +16 dBm, or $\pm 2$ V DC or AC pk   |
| Bandwidth                                    | 1 GHz, DC coupled   |
| Trigger polarity                             | Selectable rising or falling edge   |
| Trigger level                                | Selectable $-1$ V to $+1$ V in steps of 1 mV  |
| Sensitivity                                  | < 50 mV pk-pk DC to 100 MHz, rising linearly to 100 mV pk-pk at 1 GHz                               |
| Minimum pulse width                          | 500 ps at 100 mV pk-pk  |
| <b>EXTERNAL TRIGGER OUTPUT SPECIFICATION</b> |   |
| Trigger output pulse                         | Fixed amplitude and timing parameters, positive edge polarity, trigger is leading edge              |
| Impedance                                    | 50 $\Omega$ , $\pm 0.5$ $\Omega$  |
| Connector                                    | SMA(f)  |
| Amplitude and offset                         | > 700 mV fixed, on logic low of 0 V $\pm$ < 100 mV  |
| Pulse width                                  | 500 ns, $\pm 100$ ns  |
| Trigger to trigger output delay              | 4 ns, $\pm 1$ ns  |
| Trigger to trigger output jitter             | 2.5 ps RMS typical. 3 ps RMS maximum.   |
| Transition time                              | < 400 ps (10% to 90%)   |
| <b>GENERAL SPECIFICATIONS</b>                |   |
| AC to DC adaptor                             | 5 V $\pm 5\%$ at 1.6 A, 8 W, universal plug (adaptor included)                                      |
| PC connection                                | USB 2.0 (USB 1.1 and USB 3.0 compatible), 1.8 m USB 2.0 lead included                               |
| PC requirements                              | Windows XP SP3 to Windows 8   |
| Operating temperature range                  | +5 $^{\circ}$ C to +35 $^{\circ}$ C   |
| Storage temperature range                    | -20 $^{\circ}$ C to +50 $^{\circ}$ C  |
| Temperature range for stated specifications  | +15 $^{\circ}$ C to +25 $^{\circ}$ C or $T_{CAL}$ (temperature of calibration) $\pm 5$ $^{\circ}$ C |
| Operating humidity range                     | < 85% RH (non-condensing) at +35 $^{\circ}$ C   |
| Storage humidity range                       | < 95% RH (non-condensing)   |
| Altitude range                               | Up to 2000 m  |
| Pollution degree                             | 2   |
| Ingress protection                           | IP20  |
| Dimensions (instrument)                      | 190 mm W x 180 mm D x 40 mm H   |
| Weight (instrument)                          | 560 g   |

Specifications describe guaranteed performance over the stated temperature range and apply after the instrument's temperature has been stabilized in 1 hour of continuous operation. All specifications are subject to change without notice.

Factory calibration cycle. For optimum performance, the instrument should have a complete verification of specifications once every 12 months.

## Front and rear panels

### PicoSource PG911



SRD  
pulse outputs

Trigger output  
and input

### PicoSource PG914



SRD  
pulse outputs

TD pulse head  
drive outputs

Trigger output  
and input

### PicoSource PG912



TD pulse head  
drive outputs

Trigger output  
and input

### All models



DC  
power  
input

USB  
port

Signal  
ground  
terminal

## Optional accessories

| MODEL | DESCRIPTION   |  | USD* | EUR* | GBP* |
|-------|---|--|------|------|------|
| TA237 | 14 GHz 25 ps TDR kit<br><ul style="list-style-type: none"> <li>• 18 GHz 50 <math>\Omega</math> SMA(m-m) within-series adaptor</li> <li>• 18 GHz SMA(f) reference short</li> <li>• 18 GHz SMA(f) reference load</li> </ul>                       |    | 329  | 289  | 229  |
| TA238 | 14 GHz power divider kit<br><ul style="list-style-type: none"> <li>• 18 GHz 50 <math>\Omega</math> SMA(f-f-f) 3-resistor 6 dB power divider</li> <li>• 2 x 10 cm precision coaxial SMA(m-m) cable</li> </ul> For use with PicoScope 9300 Series |    | 539  | 479  | 379  |
| TA181 | Attenuator 3 dB<br>10 GHz 50 $\Omega$ SMA (m-f)   |    | 75   | 67   | 53   |
| TA261 | Attenuator 6 dB<br>10 GHz 50 $\Omega$ SMA (m-f)   |    | 75   | 67   | 53   |
| TA262 | Attenuator 10 dB<br>10 GHz 50 $\Omega$ SMA (m-f)  |    | 75   | 67   | 53   |
| TA173 | Attenuator 20 dB<br>10 GHz 50 $\Omega$ SMA (m-f)  |   | 75   | 67   | 53   |
| TA172 | 18 GHz, 50 $\Omega$ N(f) -SMA(m) inter-series adaptor   |  | 129  | 119  | 92   |
| TA170 | 18 GHz 50 $\Omega$ SMA(m-f) connector saver adaptor   |  | 20   | 18   | 14   |
| TA263 | 60 cm precision high-flex unsleeved coaxial cable<br>SMA(m-m)<br>< 1.7 dB loss @ 10 GHz   |  | 75   | 67   | 53   |
| TA264 | 30 cm precision high-flex unsleeved coaxial cable<br>SMA(m-m)<br>< 1.1 dB loss @ 10 GHz   |  | 65   | 58   | 46   |
| TA265 | 30 cm precision sleeved coaxial cable<br>SMA(m-m)<br>< 1.1 dB loss @ 10 GHz   |  | 65   | 58   | 46   |

\* Prices correct at the time of publication. VAT not included. Please contact Pico Technology for the latest prices before ordering.



**PicoSource PG911**



**PicoSource PG912**



**PicoSource PG914**

**KIT CONTENTS**

**All kits contain:**

PicoSource PG900 software disk • Quick Start Guide • AC to DC adaptor 5 V DC at 2 A, universal input  
 USB 2.0 cable 1.8 m • SMA/PC3.5/2.92 wrench • Storage and carry case

| DESCRIPTION   | ORDER CODE               | PG911 | PG912 | PG914 |
|---|--------------------------|-------|-------|-------|
| Positive 40 ps tunnel diode pulse head (attached to the device) | Not available separately |       | •     | •     |
| Negative 40 ps tunnel diode pulse head (attached to the device) | Not available separately |       | •     | •     |
| 12 GHz N(f) to SMA(m) adaptor (2 pack)                          | TA172                    |       | •     | •     |
| 10 GHz 20 dB SMA(m-f) attenuator (2 pack)                       | TA173                    | •     |       | •     |
| 50 Ω coaxial SMA(m-m) pulse drive cable 60 cm (2 pack)          | Not available separately |       | •     | •     |

**Ordering information**

| MODEL            | ORDER CODE | PULSE GENERATOR  | USD*   | EUR*   | GBP* |
|------------------|------------|--|--------|--------|------|
| PicoSource PG911 | PP977      | 50 Ω SMA(f) < 60 ps differential pulse outputs, 2.5 V to 6 V variable amplitude            | 8095   | 7215   | 5675 |
| PicoSource PG912 | PP978      | 50 Ω N(m) < 40 ps positive and negative tunnel diode pulse heads, > 200 mV fixed amplitude | 10 585 | 9435   | 7425 |
| PicoSource PG914 | PP979      | Dual-mode generator with both of the above outputs   | 13 075 | 11 645 | 9175 |

**UK global headquarters:**

Pico Technology  
 James House  
 Colmworth Business Park  
 St. Neots  
 Cambridgeshire  
 PE19 8YP  
 United Kingdom

+44 (0) 1480 396 395  
 sales@picotech.com

**North America regional office:**

Pico Technology  
 320 N Glenwood Blvd  
 Tyler  
 Texas 75702  
 United States

+1 800 591 2796  
 sales@picotech.com

**Asia-Pacific regional office:**

Pico Technology  
 Room 2252, 22/F, Centro  
 568 Hengfeng Road  
 Zhabei District  
 Shanghai 200070  
 PR China

+86 21 2226-5152  
 pico.china@picotech.com

\*Prices correct at the time of publication. Sales taxes not included. Please contact Pico Technology for the latest prices before ordering.

Errors and omissions excepted. *Windows* is a registered trade mark of Microsoft Corporation in the United States and other countries. *Pico Technology*, *PicoSource* and *PicoScope* are internationally registered trade marks of Pico Technology Ltd.

MM070.en-7. Copyright © 2015–2019 Pico Technology Ltd. All rights reserved.

[www.picotech.com](http://www.picotech.com)



Pico Technology



@LifeAtPico



@picotechnologyltd



Pico Technology



@picotech